

*WiMAX Solutions
Division*

IEEE 802.16e-2005 Air Interface Overview

Kuo-Hui Li, PhD
WiMAX Solutions Division
Intel Mobility Group
June 05, 2006

802.16 Air Interface Standards

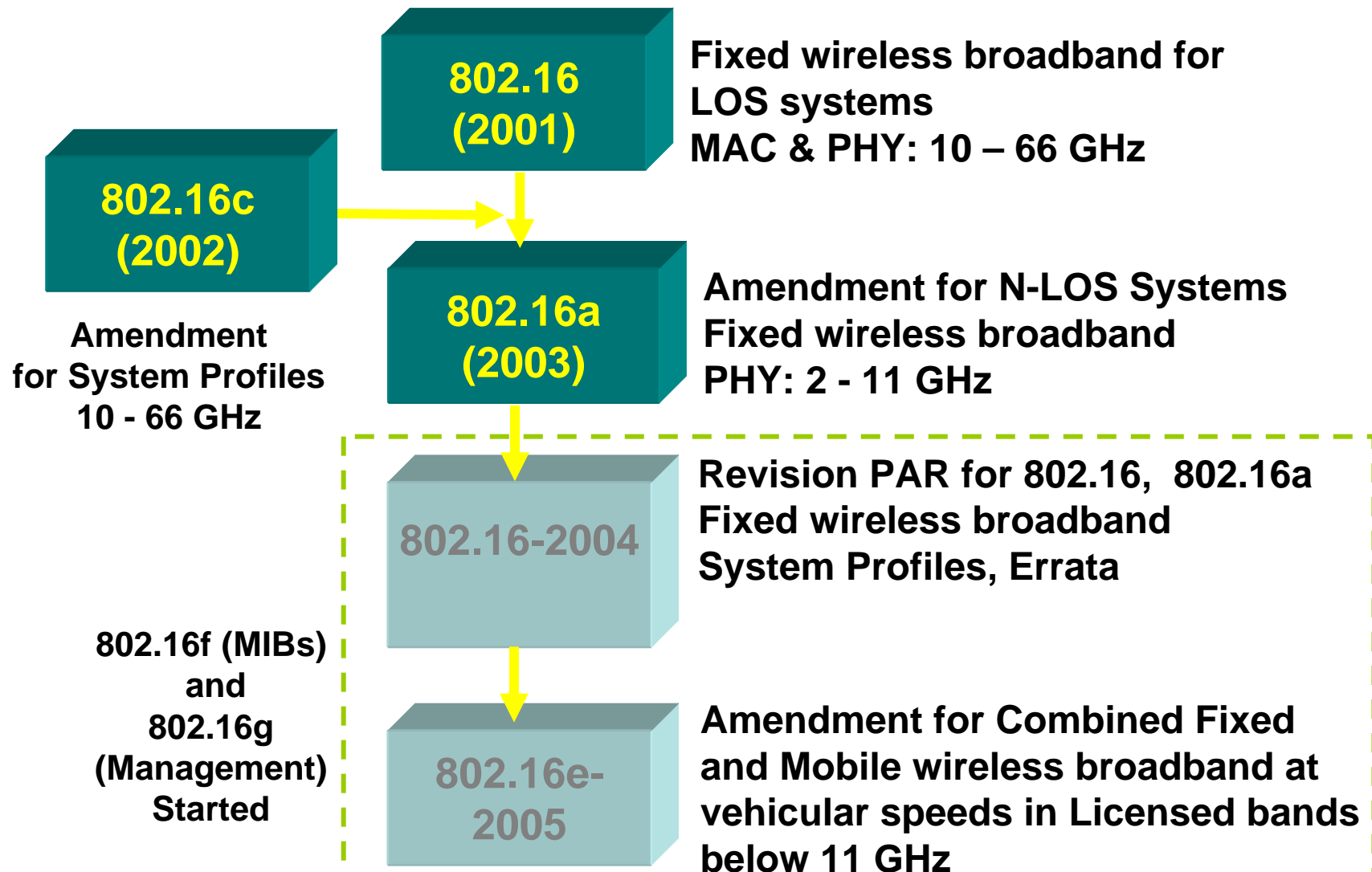

802.16e-2005 Protocol Stack

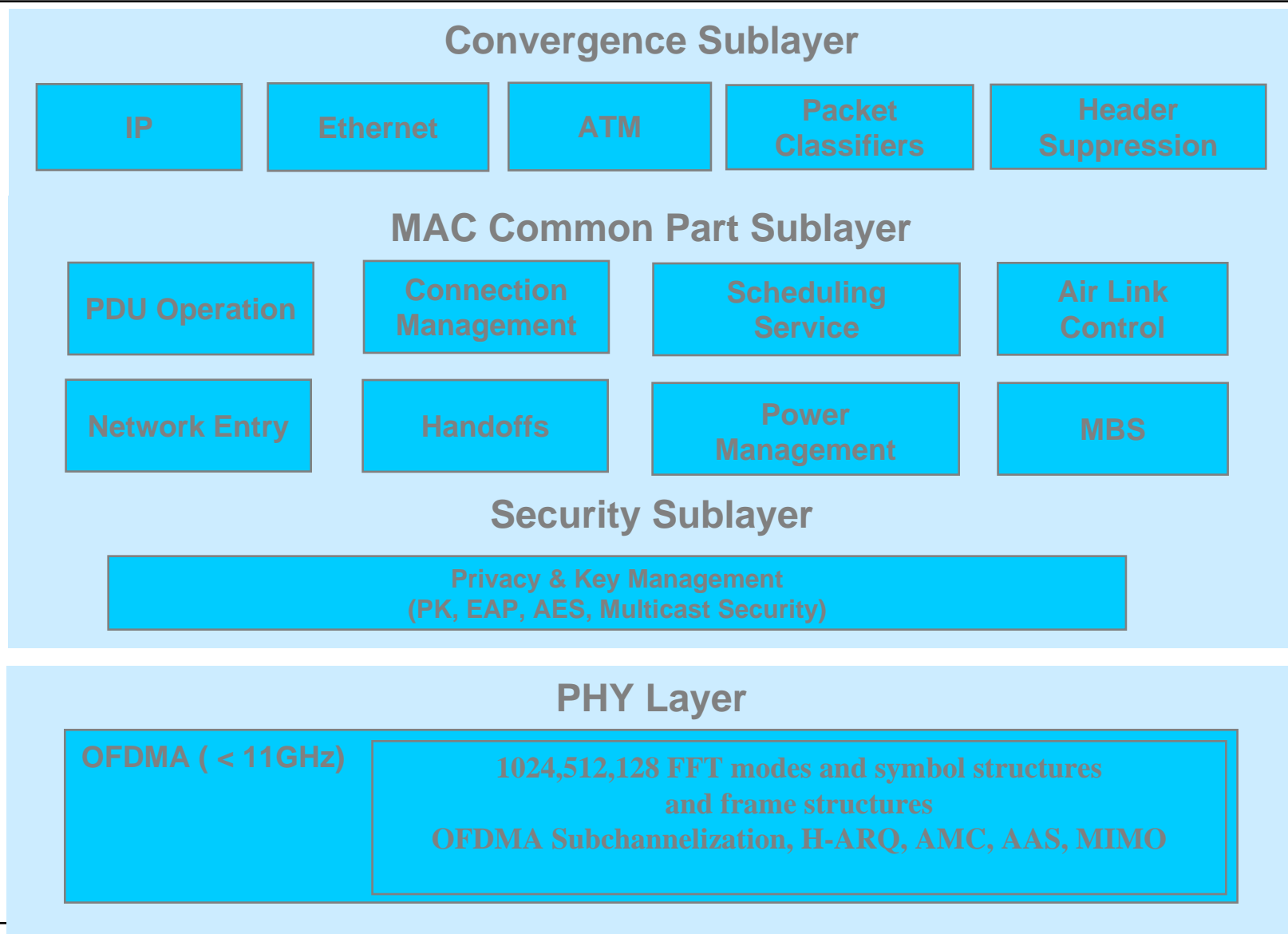

IEEE 802.16e-2005 Features

Scalability	Scalable PHY for capable of 1.25-20 MHz. Mobile WiMAX Global Profiles of 5 & 10MHz proposed. Flexible frequency re-use schemes for network planning.
High Data Rates	Larger MAC frames with low overhead, Advanced FEC, Adaptive modulation, H-ARQ for reducing packet loss, Full MIMO and Beamforming support
QoS	Traffic types, QoS with Service Flows, Advanced Scheduling Framework, Adaptive Modulation & Coding, ARQ, H-ARQ
Mobility	Secure Optimized Hard Handover, Fast BS Switching Handover, Power Management with Sleep and Idle modes
Security	EAP authentication, Encryption with AES-CCM, CMAC Authentication mode, X.509 Certificates, Key Binding, Device and User authentication capability

PHY Overview

- OFDM/OFDMA fundamentals
- OFDMA sub-channelization
- Frame structure
- Tx-Rx structure
- MIMO
- PHY profiles

Wireless Fading Channel Characteristics

Multipath Fading Channel

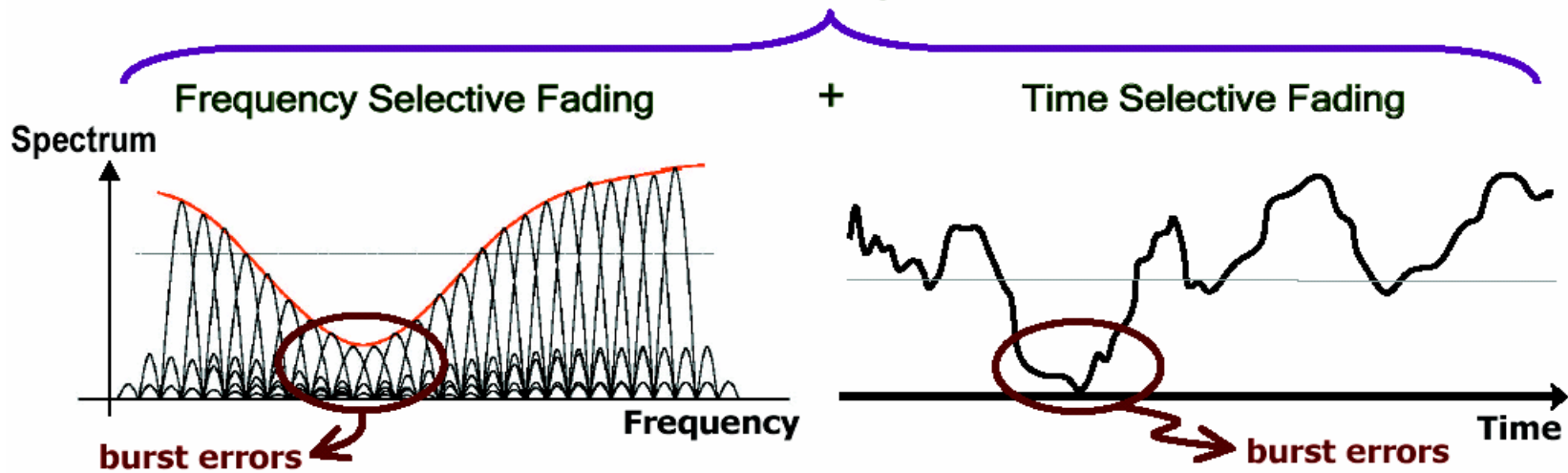

Instantaneous Impulse Response

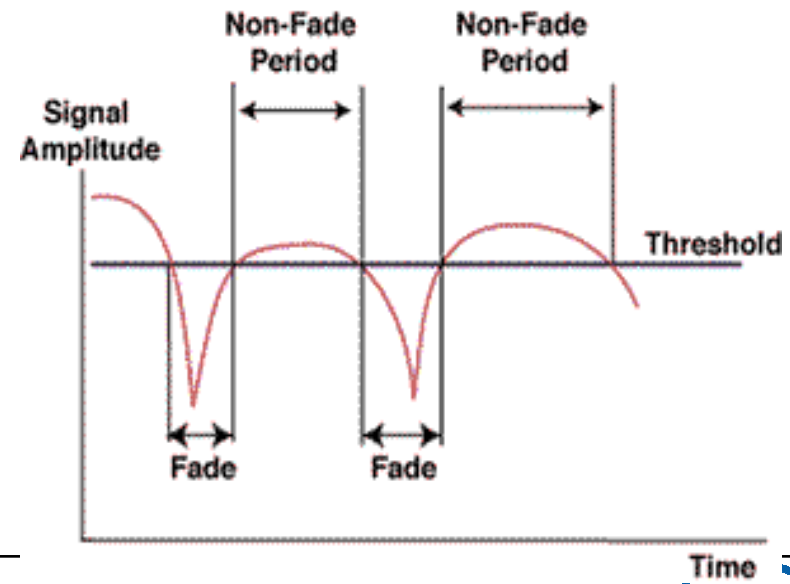
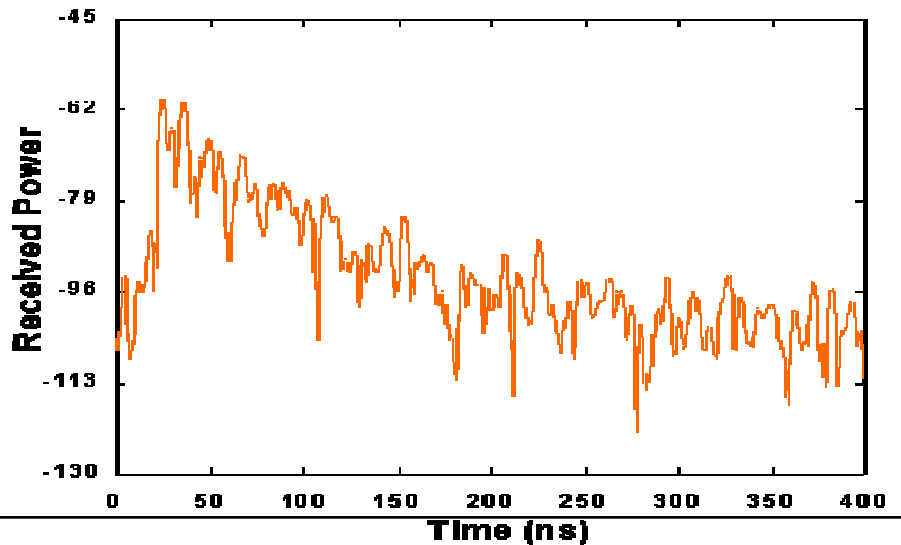

OFDM Basics

- Orthogonal frequency division multiplexing
- Frequency-selective wideband channel →
Parallel orthogonal flat narrowband channels

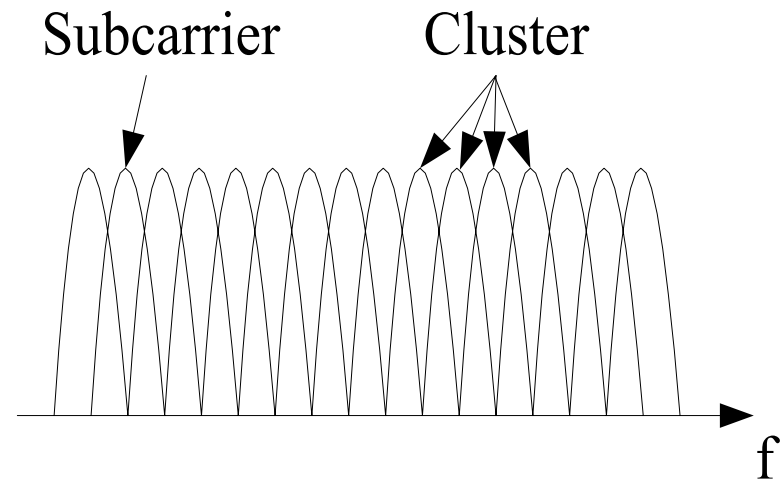
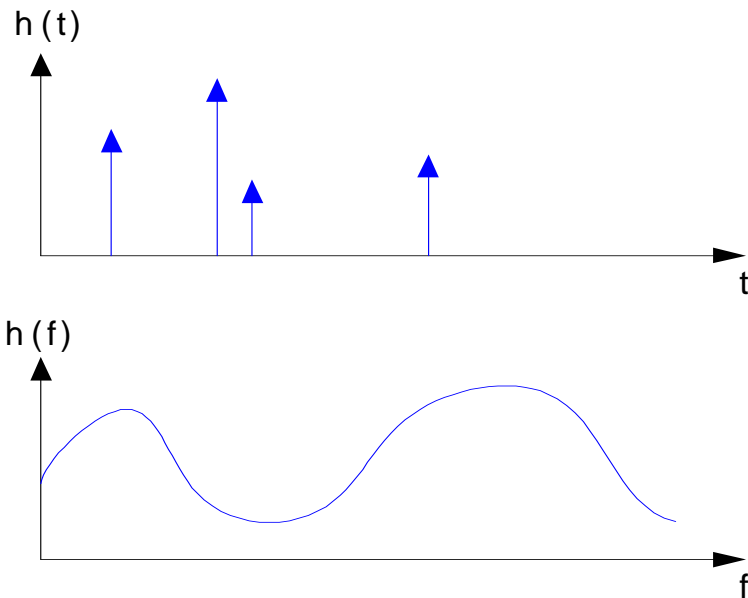

OFDM Modulation

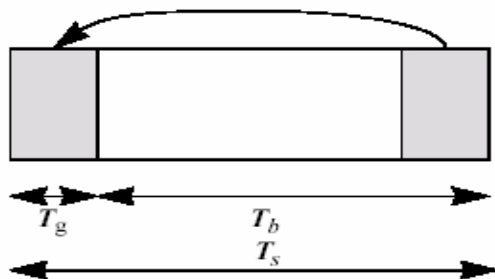
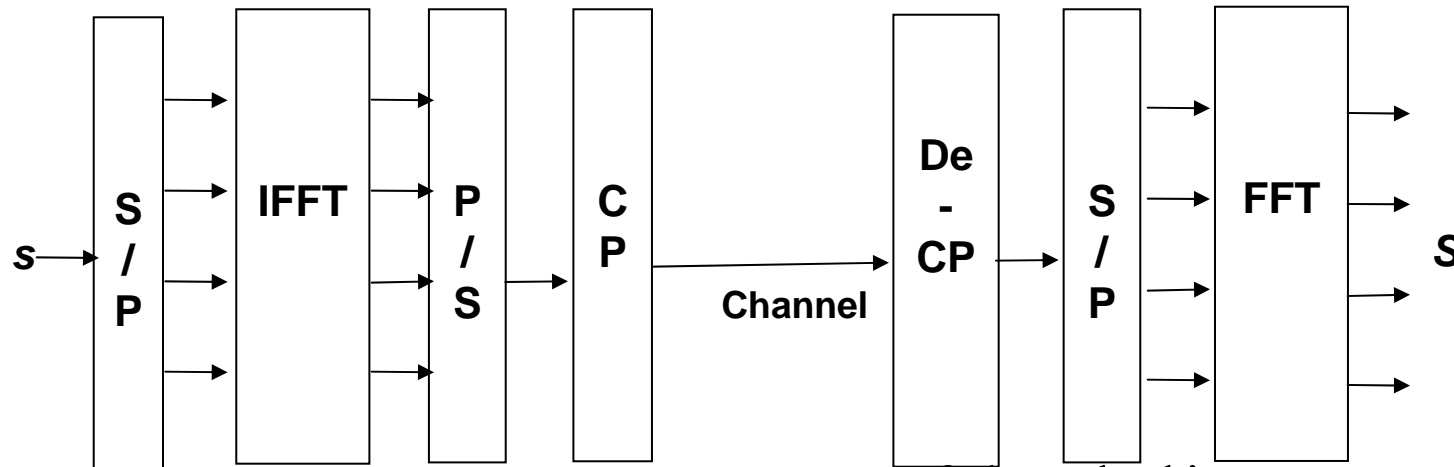

- T_b : useful symbol time

- T_g : OFDM cyclic prefix (CP)

- $T_s = T_b + T_g$: OFDM symbol duration

- CP: a portion of the last useful OFDM symbol being pre-pended
- Immune to multipath while maintaining the orthogonality of the tones

$$FFT(\mathbf{s} \otimes \mathbf{h}) = FFT(\mathbf{s}) \bullet FFT(\mathbf{h})$$

OFDMA

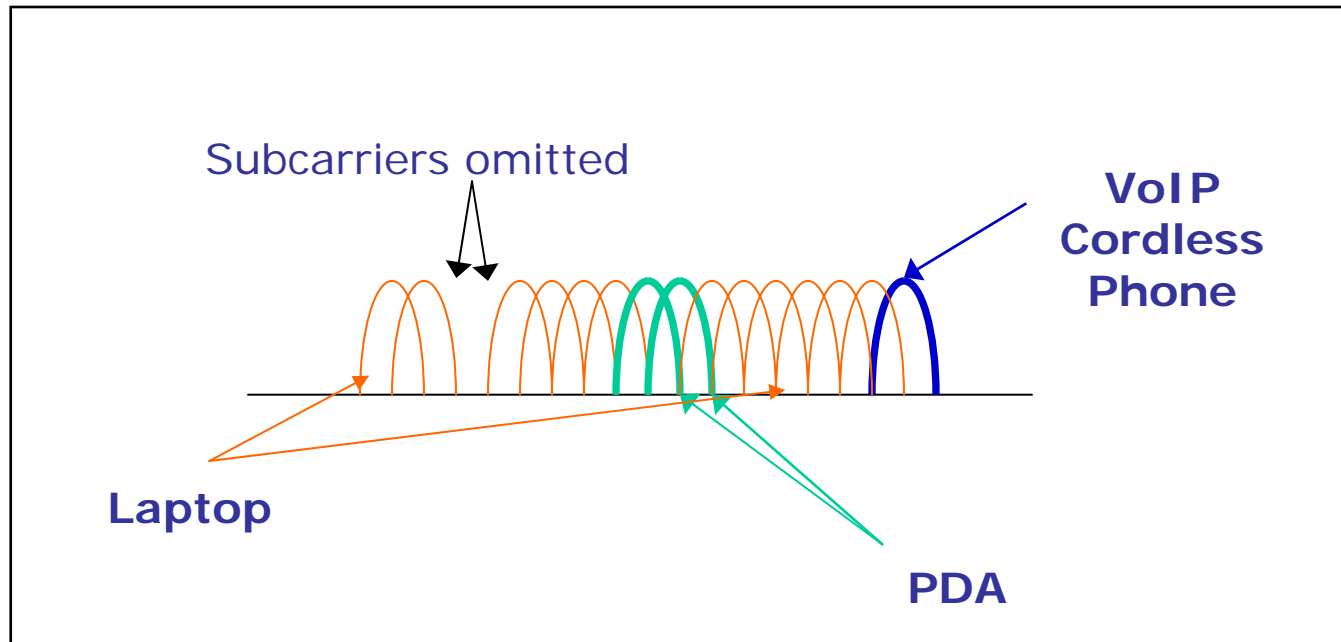

- Multiple access based on OFDM
- High granularity bandwidth allocation
- Avoid subcarriers in deep fades
- Excellent signal isolation between subcarriers

OFDMA – Multi User Access

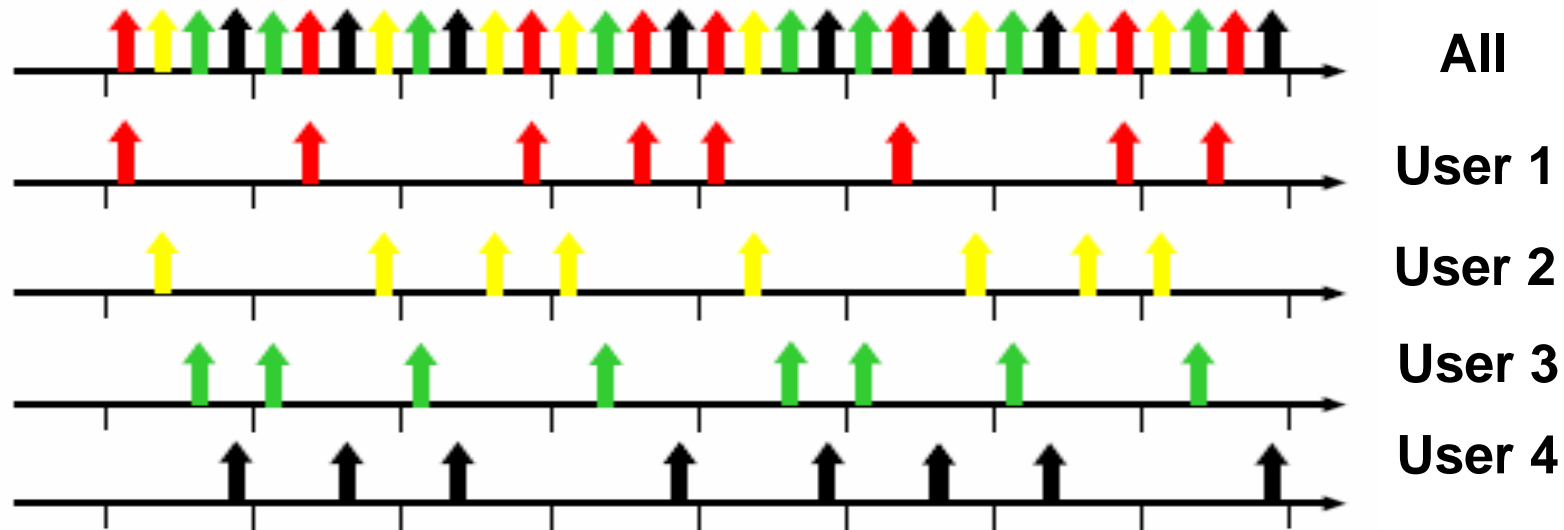

- Multiple users keep orthogonal subchannels during multiple access
 - Reduce interference
 - Improve capacity
- Flexible subchannelization
 - Pseudo-random permutation for diversity
 - Contiguous permutation for selectivity
- High granularity bandwidth allocation
- Scalable structure

OFDMA Scalability

- Broadband wireless spectrum worldwide is not fully harmonized
- CDMA does not scale well with multiple channel bandwidths
 - CDMA 2000 = 1.25MHz channels
 - WCDMA/HSDPA = 5 MHz channels
- OFDMA allows for optimal operation in varying channel widths
 - OFDMA = 1.25 MHz, 2.5, 5, 10, 14 and 20 MHz channels

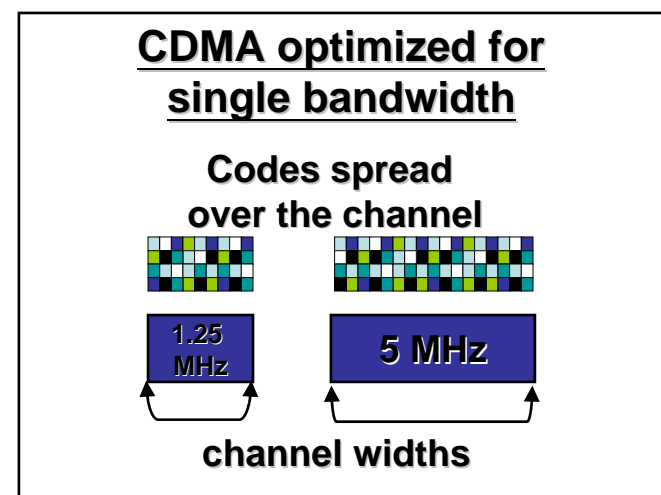
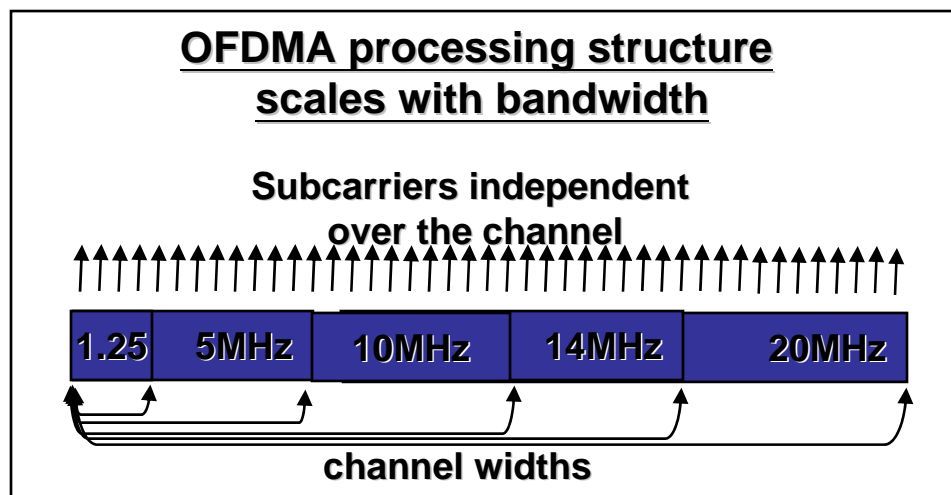

Subchannel Permutation Options

- Diversity permutation
 - Downlink FUSC
 - Downlink PUSC
 - Uplink PUSC
- Contiguous permutation
 - Downlink Band AMC
 - Uplink Band AMC

OFDMA Sub-channel Permutation

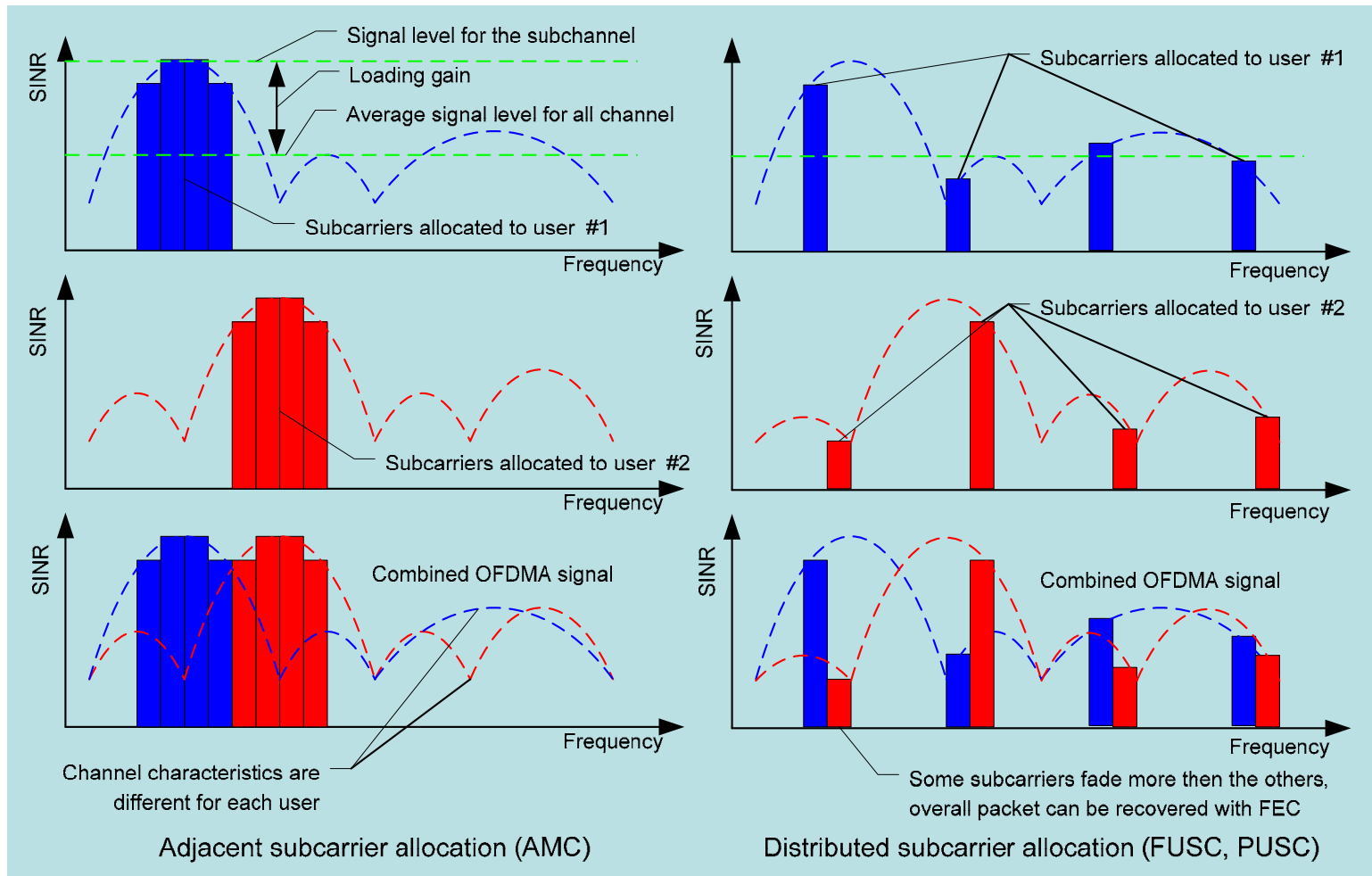

- Contiguous permutation: AMC
- Diversity permutation: FUSC, PUSC

Permutation Summary

- Diversity permutation
 - Asymmetric downlink/uplink permutation
 - Frequency diversity
 - Interference averaging
- Contiguous permutation
 - Symmetric downlink/uplink permutation
 - Frequency coherence for loading and beamforming
 - Multiuser diversity
 - No interference averaging
- Subchannelization
 - Orthogonal subchannels
 - Three segments for inband frequency reuse
- Permutations can not co-exist in one OFDM symbol
 - Multiple permutations can be support in different zones

Permutation Tradeoff

	Adjacent subcarrier permutation (AMC)	Diversity subcarrier permutation (PUSC, FUSC)
Benefits	Sub-channelization gain; Frequency selective loading gain	Sub-channelization gain; Frequency diversity; Inter-cell Interference averaging
Scheduling	Advanced frequency scheduler to explore frequency selectivity gain	Simple scheduler; Rely on frequency diversity to achieve robust transmission
Channel condition	Stationary channel	Fast-changing channel
Favorable smart antenna technology	Beamforming	MIMO

OFDMA TDD Frame Structure

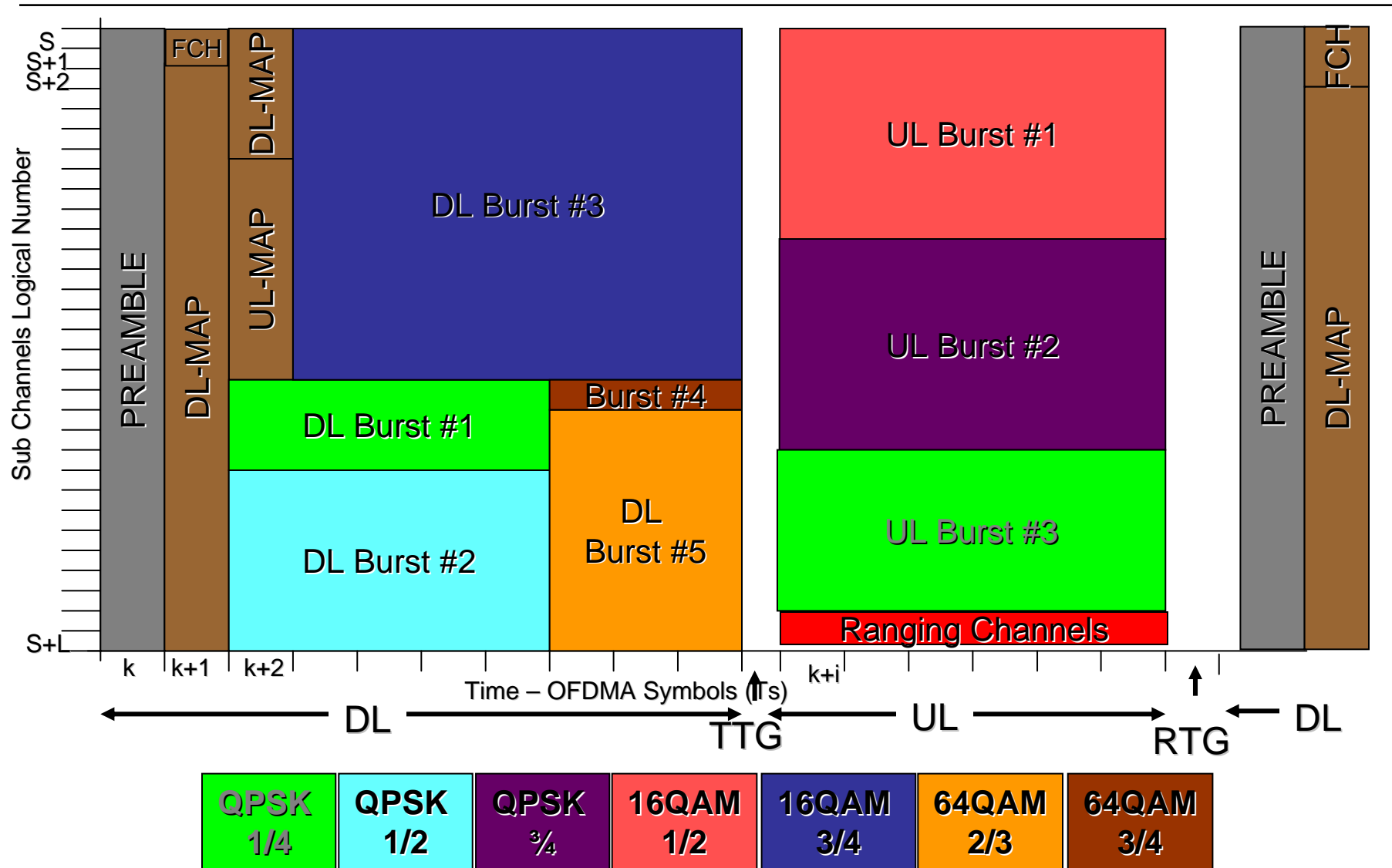

OFDMA Permutation Zones

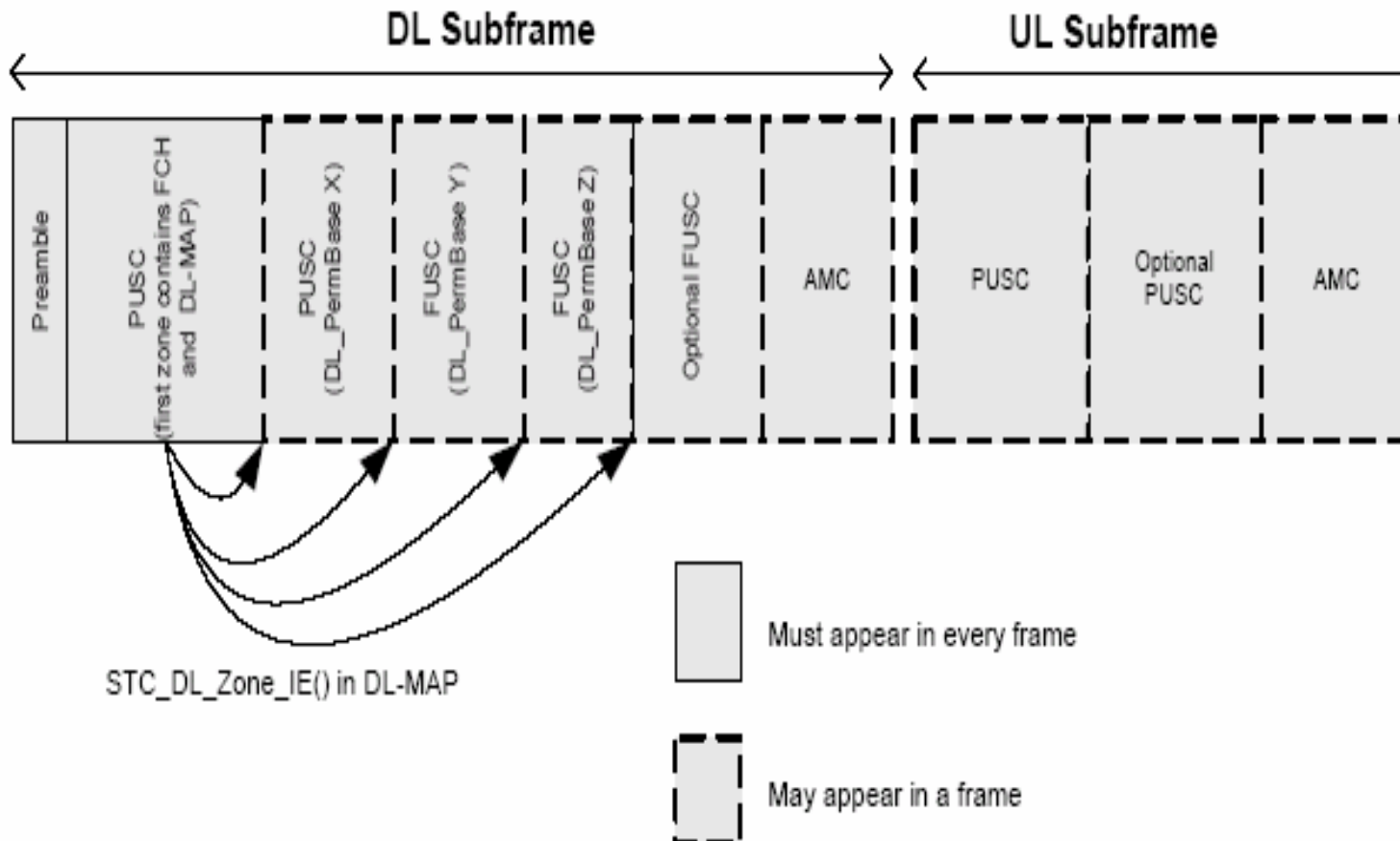

Fractional Frequency Reuse

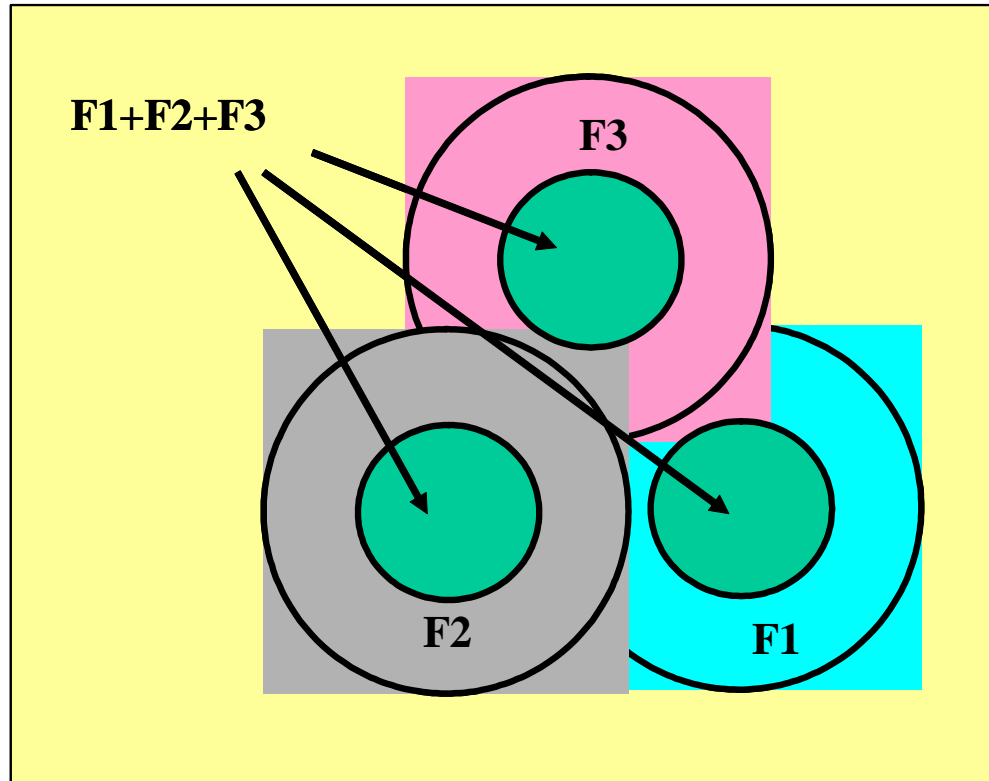

- Support frequency reuse one
- No frequency planning
- Frequency reuse one at cell center to maximize spectral efficiency
- Higher reuse factor at cell edge to reduce interference
- Flexible reconfiguration

Advanced Antenna System Support

Link	Beam forming	Space Time Coding	Spatial Multiplexing
DL	$N_t \geq 2, N_r \geq 1$	$N_t = 2, N_r \geq 1$ Matrix A	$N_t = 2, N_r = 2$ Matrix B, vertical encoding
UL	$N_t = 1, N_r \geq 2$	N/A	$N_t = 1, N_r \geq 2$ Two-user collaborative SM

- AAS (beamforming)
 - Improve link budget
 - Reduce interference
 - Minor change to client
 - #Antennas ≥ 4 for good beamforming effect
 - Requires CSI feedback (e.g. sounding), good for slow varying channel
 - Only extends range for unicast transmission
- Space time code (STC)
 - Reduce fade margin by spatial diversity
 - Open loop
 - Peak rate limit
- Spatial multiplexing (SM)
 - Improve capacity
 - Open loop
 - Requires good SINR and low spatial correlation
- Adaptive MIMO switch (AMS)
 - Optimally select STC or SM to adapt to channel condition
 - Reduced feedback
 - Explore spatial diversity with 2x2 antenna configuration



MIMO-OFDMA Architecture

MIMO operation on frequency domain

- Flat subcarriers - h_{ij} is scalar
- Simple frequency domain equalizer
- Scalable with bandwidth

$$\mathbf{H} = \begin{bmatrix} h_{11} & h_{21} \\ h_{12} & h_{22} \end{bmatrix}$$

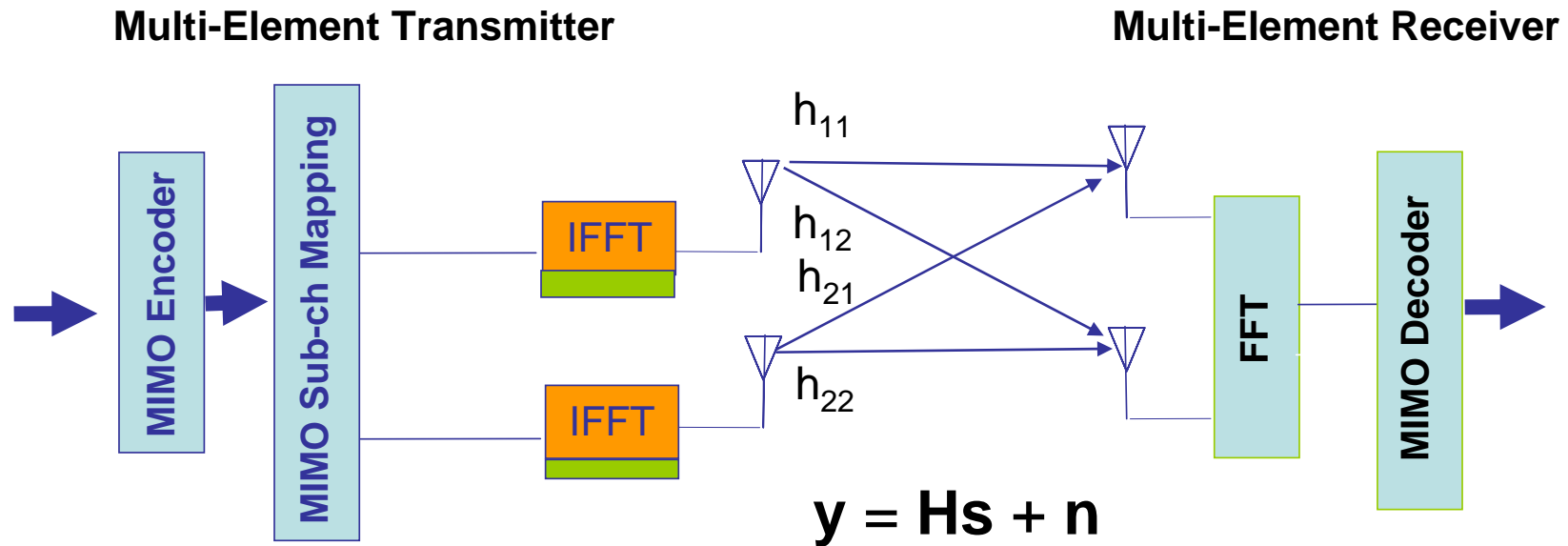

DL Adaptive MIMO Switching (AMS)

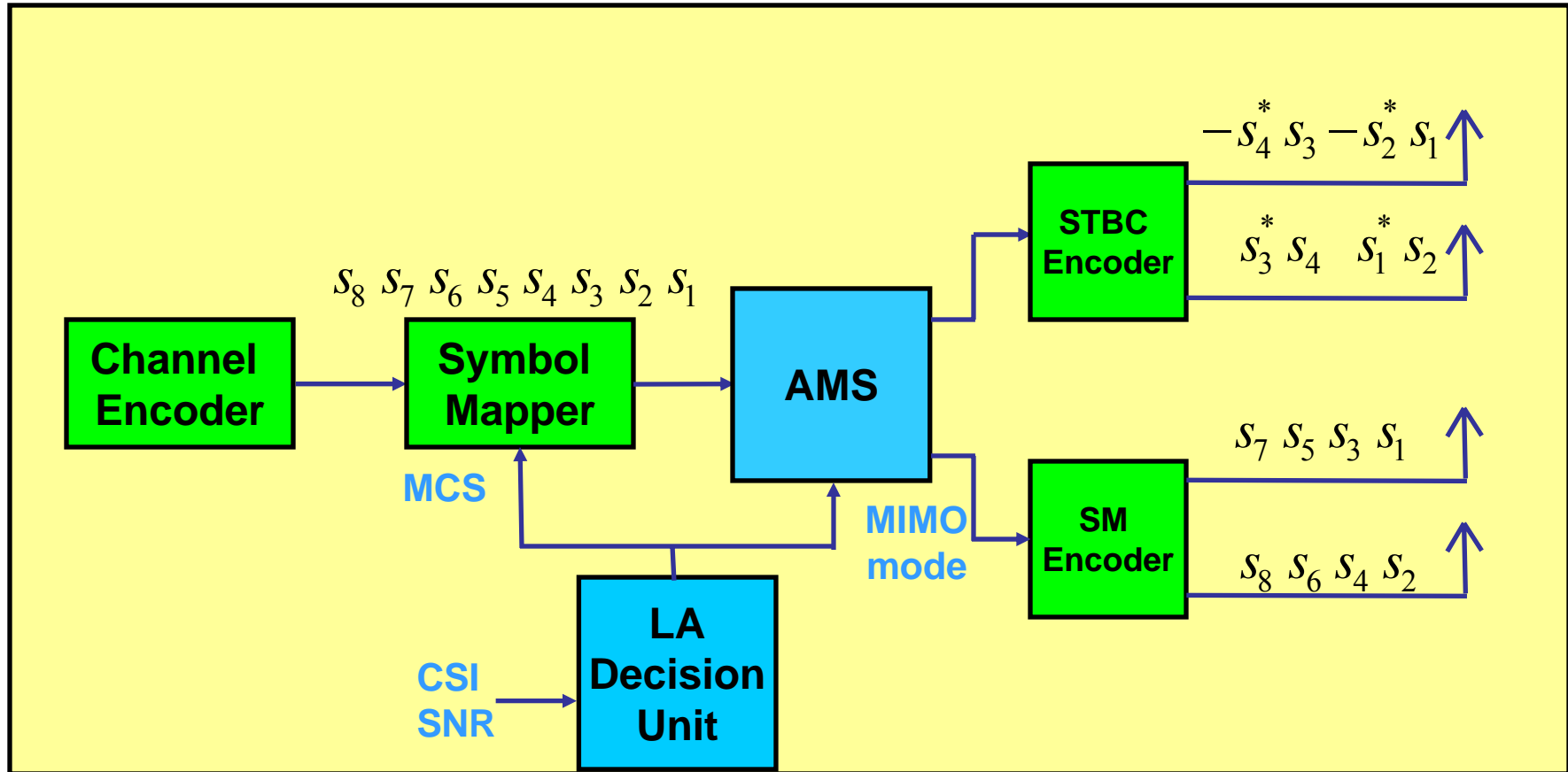

MCS: Modulation and Coding Scheme
LA: Link Adaptation
CSI: Channel State Information
SNR: Signal-to-Noise Ratio

Performance of AMS

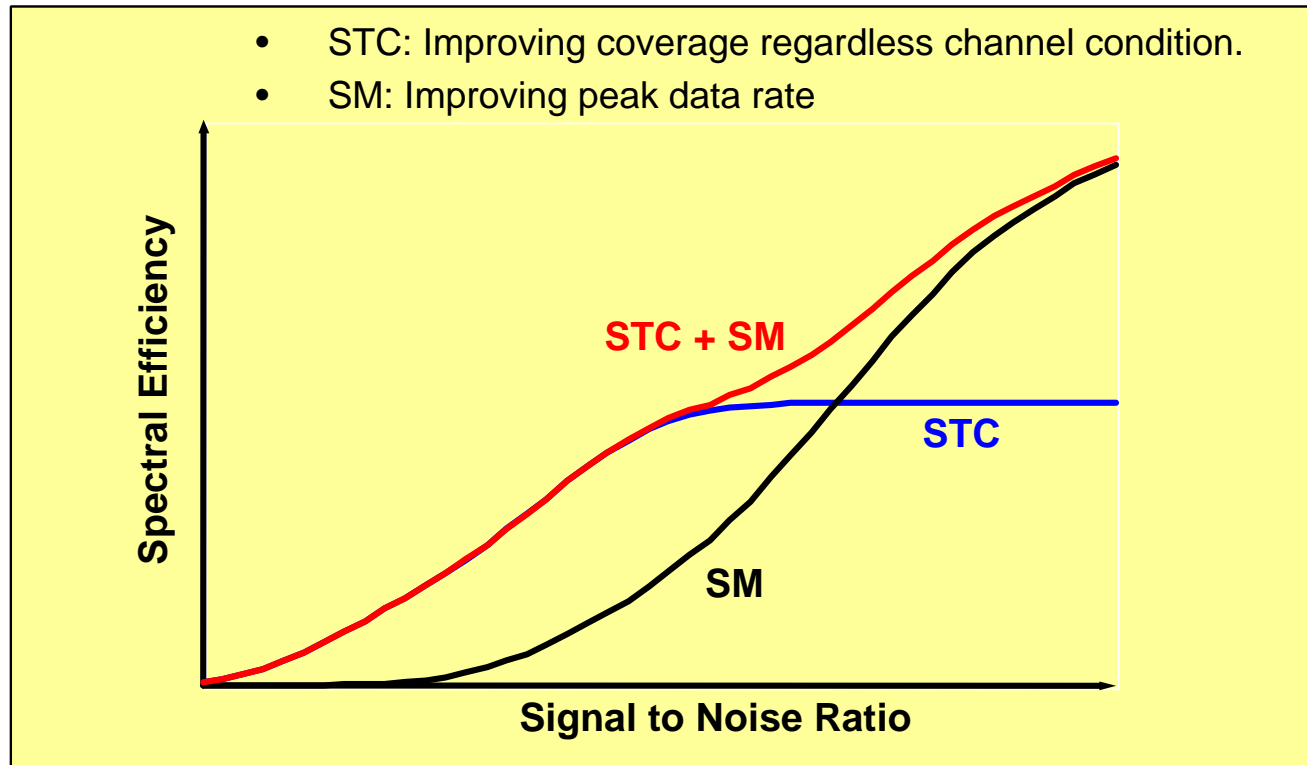

AMS overcomes the deficiencies of STBC and SM and leads to spectral efficiency very close to the ideal one at both low and high SNR regions

Up Link Collaborative MIMO

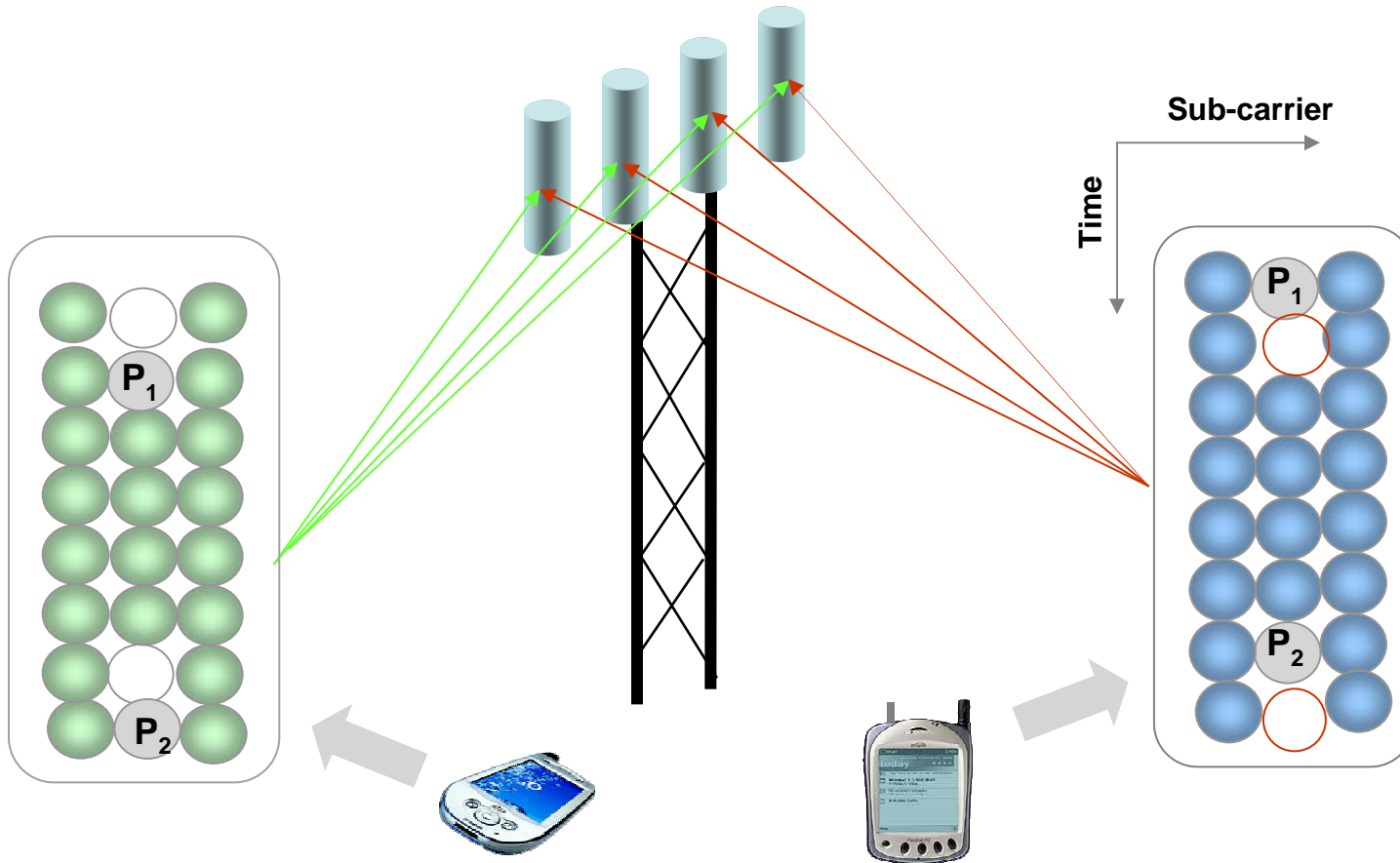

- MSs spatially uncorrelated
- Without 3dB power penalty

Duplexing

- **802.16e supports both TDD and FDD**
- **Needed to select one duplexing scheme for lower cost and interoperability**
- **The choice is TDD**
 - TDD allows flexible (system) allocation of bandwidth between uplink and downlink
 - Today most broadband data applications require higher downlink throughput
 - As the applications evolve the ratio between uplink and downlink can be changed globally
 - With a 4:1 downlink/uplink ratio, there is a downlink throughput advantage of 60% with TDD; with a 2:1 ratio the advantage is 33%
 - TDD allows more effective MIMO techniques
 - TDD channels are reciprocal and hence allow a larger and more efficient set of MIMO techniques
 - **TDD transceiver design is cheaper and less complex**

Channel and Bandwidth Classes

Band Class Index	Frequency Range (GHz)	Channel Bandwidth(s) (MHz)	FFT Size
1	2.3 - 2.4	5	512
		10	1024
		8.75	1024
2	2.305 - 2.320, 2.345 - 2.360	3.5	512
		5	512
		10	1024
3	2.496 - 2.69	5	512
		10	1024
4	3.3 - 3.4	5	512
		7	1024
		10	1024
5	3.4 - 3.8	5	512
		7	1024
		10	1024
	3.4 - 3.6	5	512
		7	1024
		10	1024
	3.6 - 3.8	5	512
		7	1024
		10	1024

Modulation/Coding

Feature	Value
Forward Error Correction	Tail Biting CC, CTC without H-ARQ CTC with Chase Combining H-ARQ CTC with Incremental Redundancy H-ARQ*
Modulation Types for CC	QPSK-1/2, -3/4 16QAM-1/2, -3/4 64QAM-1/2, -2/3, -3/4 (DL only)
Modulation Types for CTC	QPSK-1/2, -3/4 16QAM-1/2, -3/4 64QAM-1/2, -2/3, -3/4, -5/6 (DL only)

* Under Investigation

Adaptive Modulation-Coding Scheme

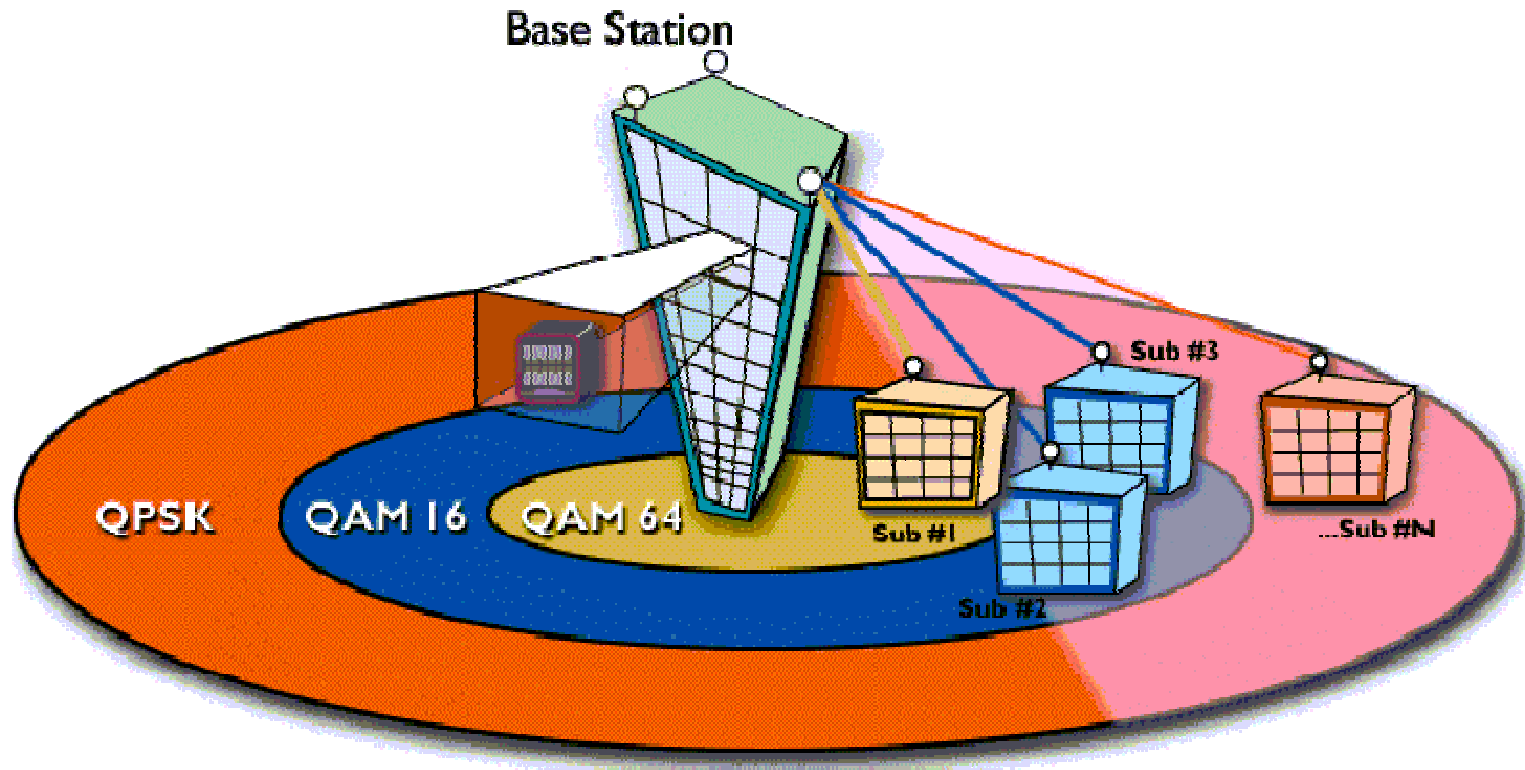

- Tradeoff between link robustness and capacity
- Adaptation on a burst by burst basis
- Modulation format BPSK/QPSK/16QAM/64 QAM

Peak TDD PHY Data Rates (kbps, DL/UL=2)

Bandwidth MCS + Repetition	5 MHz			10 MHz		
	Downlink+Uplink	Downlink	Uplink	Downlink+Uplink	Downlink	Uplink
QPSK- ½ CC, 6x	547	397	150	1102	794	309
4x	820	595	225	1653	1190	463
2x	1640	1190	450	3307	2381	926
1x	3280	2381	899	6614	4762	1852
QPSK- ¾ CC, 1x	4921	3571	1349	9921	7143	2778
16QAM ½ CC, 1x	6561	4762	1799	13228	9524	3704
16QAM ¾ CC, 1x	9841	7143	2698	19841	14286	5556
64QAM ½ CC, 1x	9841	7143	2698	19841	14286	5556
64QAM 2/3 CC, 1x	13122	9524	3598	26455	19048	7407
64QAM 3/4 CC, 1x	14762	10714	4048	29762	21429	8333

PHY Profile and Certification (1/2)

Release 1 PHY Profile		Wave 1*	Wave 2	Comments
DL Subcarrier Allocation	PUSC	●	●	
	PUSC w/ All Subchannels	●	●	
	FUSC	●	●	
	AMC 2x3		●	
UL Subcarrier Allocation	PUSC	●	●	
	AMC 2x3		●	
Ranging & Bandwidth Request	Initial Ranging	●	●	
	Handoff Ranging	●	●	
	Periodic Ranging	●	●	
	Bandwidth Request	●	●	
Fast-Feedback	6-bit	●	●	
Channel Coding	Repetition	●	●	
	Randomization	●	●	
	Convolutional Coding (CC)	●	●	
	Convolutional Turbo Coding (CTC)	●	●	
	Interleaving	●	●	
H-ARQ	Chase Combining	●	●	Wave 1 waiver on required buffer size
Synchronization	BS Time/Freq Synchronization	●	●	BS only
	BS-BS Freq Synchronization	●	●	BS only
	MSS Synchronization	●	●	MSS only
Power Control	Closed-loop Power Control	●	●	
	Open-loop Power Control	●	●	

* Wave 1 Feature Set based on results of Feb'06 WiMAX Forum

Slide31

● Full Support ◐ Partial Support

WiMAX Solutions
Division



PHY Profile and Certification (2/2)

Release 1 PHY Profile		Wave 1*	Wave 2	Comments
CINR Measurement	Physical CINR using Preamble	●	●	
	Physical CINR using Pilots	●	●	
	Effective CINR using Pilots		●	
	RSSI Measurement	●	●	
Modulation	DL QPSK	●	●	
	DL 16-QAM	●	●	
	DL 64-QAM	●	●	
	UL QPSK	●	●	
	UL 16-QAM	●	●	
	Pilot Modulation	●	●	
	Preamble Modulation	●	●	
	Ranging Modulation	●	●	
MAP Support	Normal MAP	●	●	
	Compressed MAP	●	●	
	Sub-DL-UL MAP	●	●	
MIMO (IO-MIMO for BS)	2 nd Order Matrix A/B		●	
	Collaborative Spatial Multiplexing		●	
	Fast Feedback on DL		●	
	Mode Selection Feedback w/ 6-bits		●	
	MIMO DL-UL Chase		●	
AAS/BF (IO-BF for BS)	PUSC w/ Dedicated Pilots		●	
	AMC 2x3 w/ Dedicated Pilots		●	
	UL Sounding 1 (Type A)		●	
	UL Sounding 2		●	
	CINR Measurement (Group Indication)		●	
	MIMO Permutation Feedback Cycle		●	

* Wave 1 Feature Set based on results of Feb'06 WiMAX Forum

Slide32

● Full Support ▲ Partial Support

WiMAX Solutions
Division



MAC Overview

- MAC frame format and control messages
- Network entry
- Connection management
- Scheduling services
- Air link control
- Mobility management
 - Handover
 - Sleep mode
 - Idle mode
- MBS
- MAC profiles

802.16e Protocol Stack

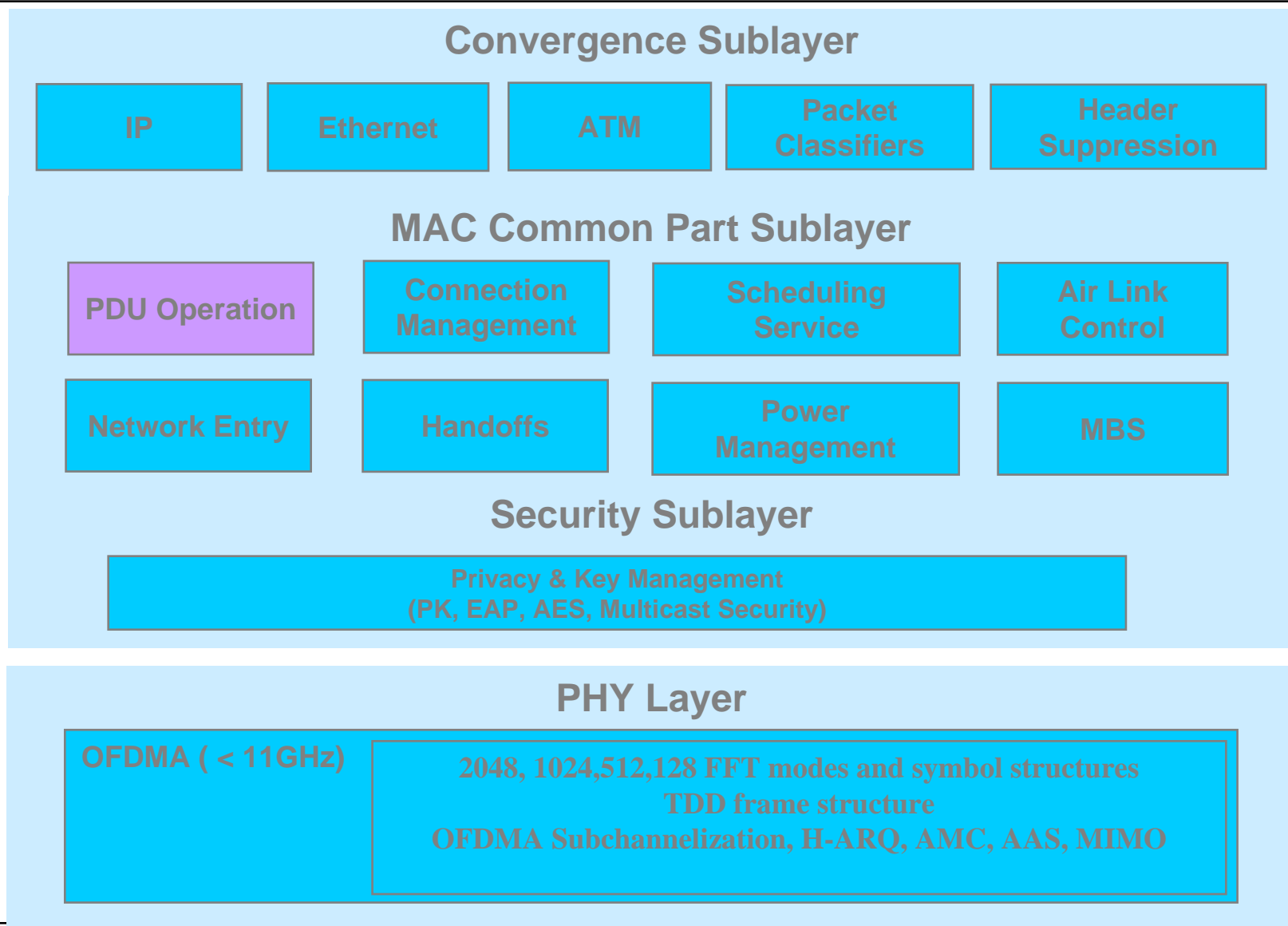

MAC PDU Format

- Each MAC PDU begins with a 6 bytes generic MAC header.
- The payload information may vary in length.
- SS has 48-bit IEEE MAC address (defined in IEEE Std. 802 – 2001)
- BS has 48-bit base station ID (24 bits operator indicator)
- Connections are identified by a 16-bit CID.
- The maximum length of the MAC PDU is 2048 bytes, including header, payload, and cyclic redundancy check (CRC).

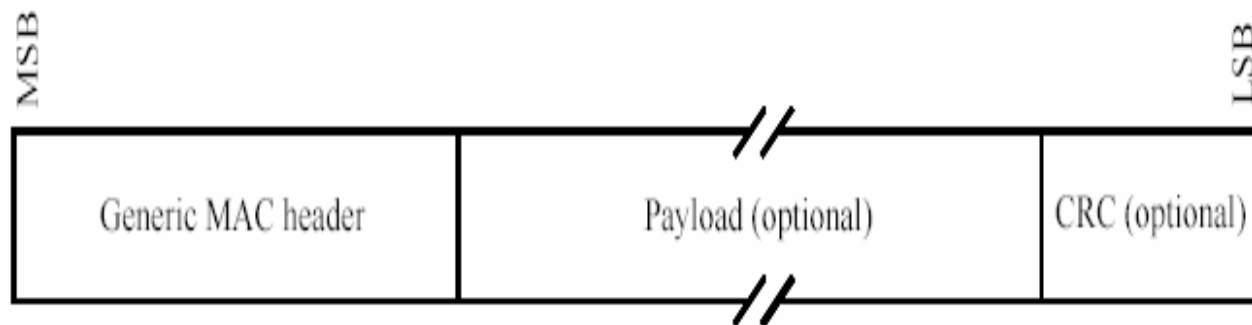

Generic MAC Header

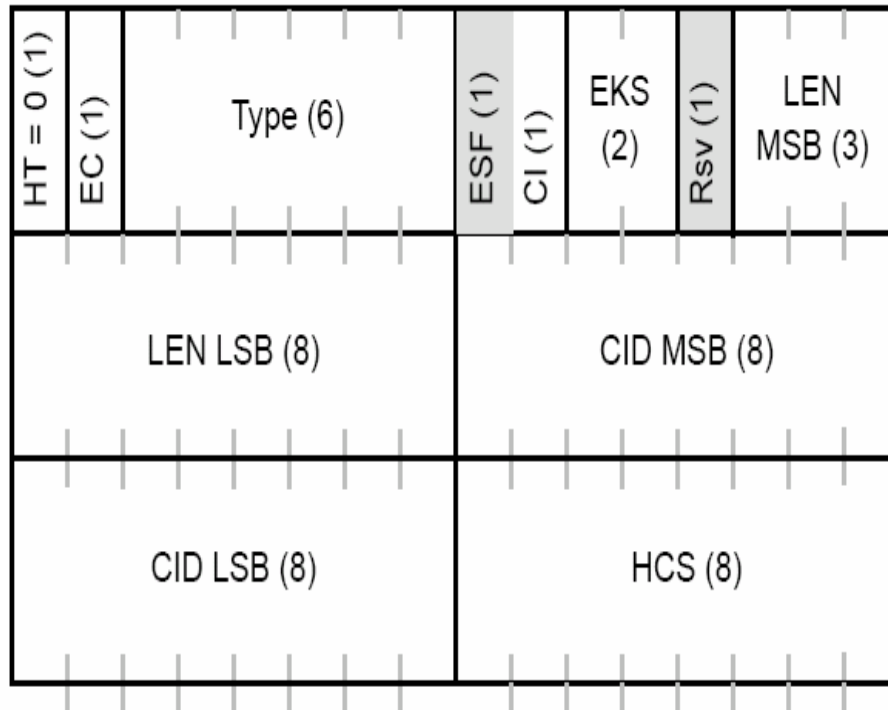

Figure 19—Generic MAC header format

HT	EC*	MAC PDU Type
0	0	Generic MAC header for DL and UL MAC PDU with data payload, no encryption, with a 6-bit type field, see Table 6 for its type field encodings.
0	1	Generic MAC header for DL and UL MAC PDU with data payload, with encryption with a 6-bit type field, see Table 6 for its type field encodings.
1	0	DL: This encoding is not defined UL: MAC signaling header type I. MAC PDU without data payload, with a 3-bit type field, see Table 5a for type encoding definitions.
1	1	DL: Compressed/Reduced Private DL-MAP** UL: MAC signaling header type II. MAC PDU without data payload, with 1-bit type field, see Table 7g for type encoding definitions.

HT: header type

ESF: extended subheader flag

EKS: Encryption Key Sequence (index of traffic encryption key)

EC: data encryption control

CI: CRC indicator

Construction of MAC PDU

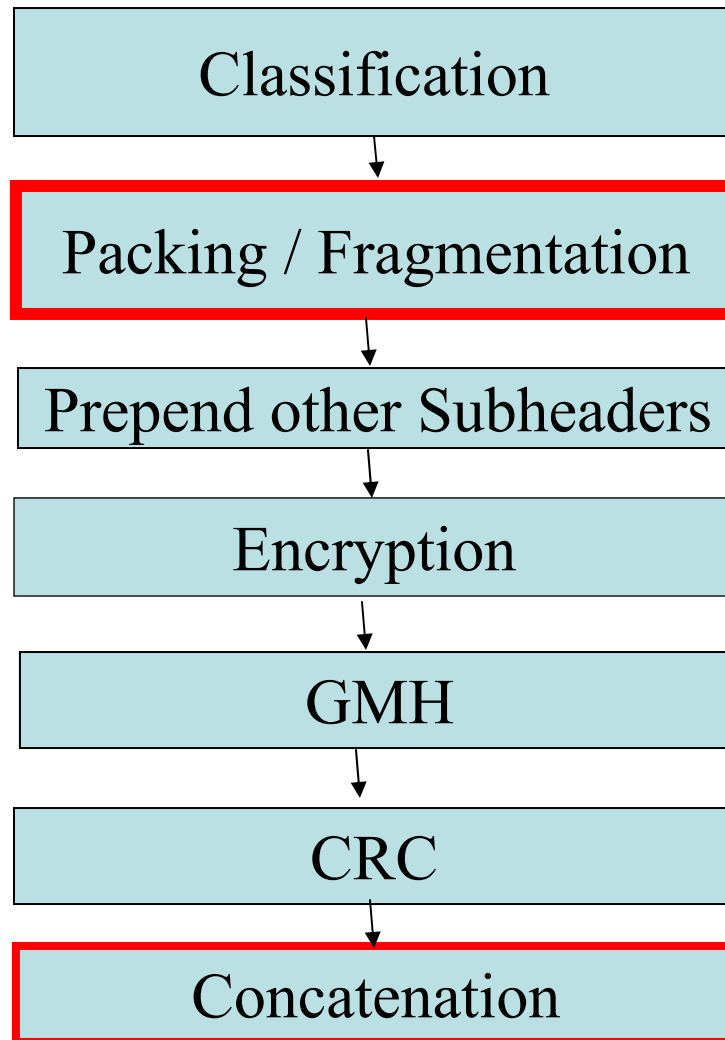

FCH Messages

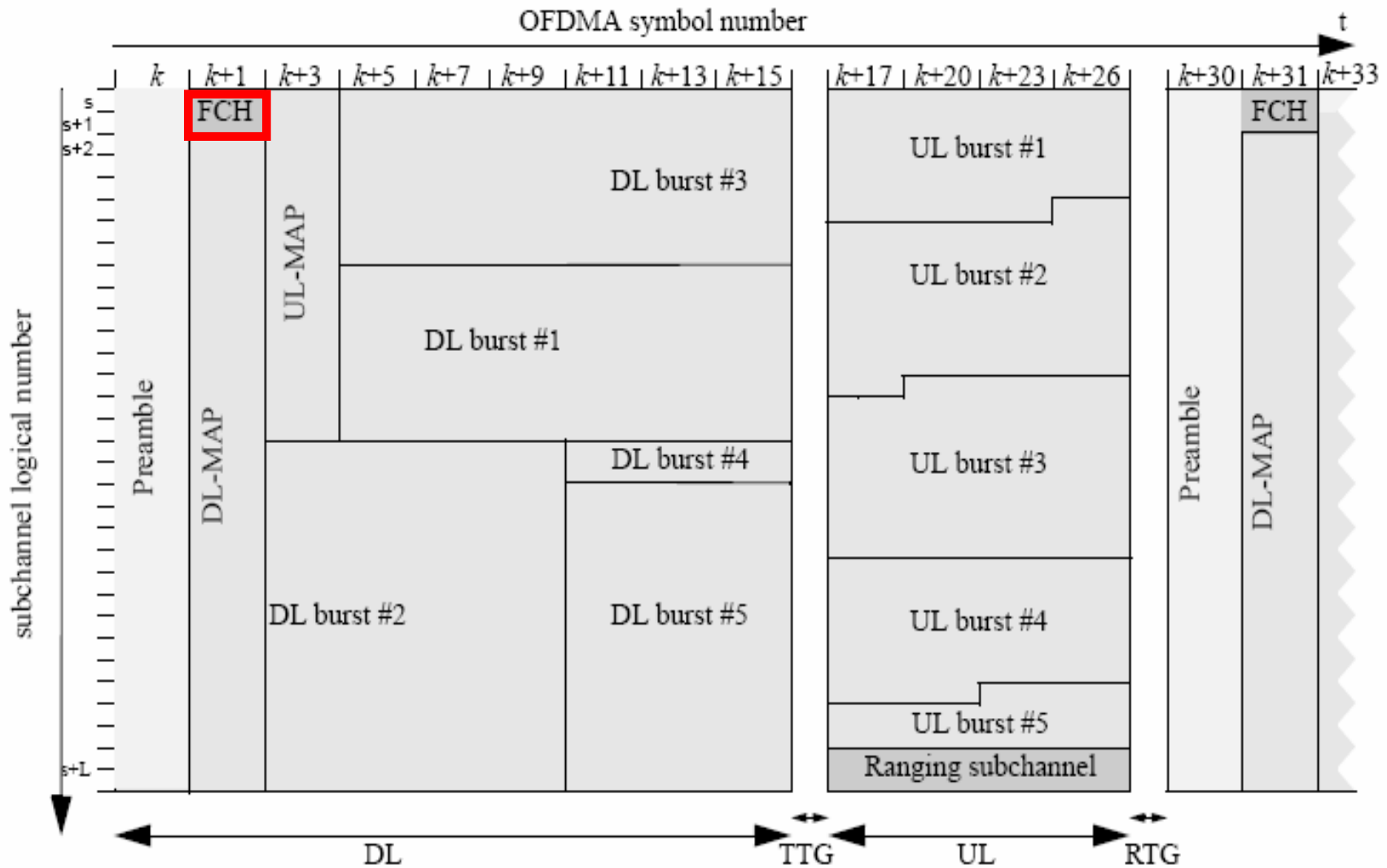

FCH – Frame Control Header

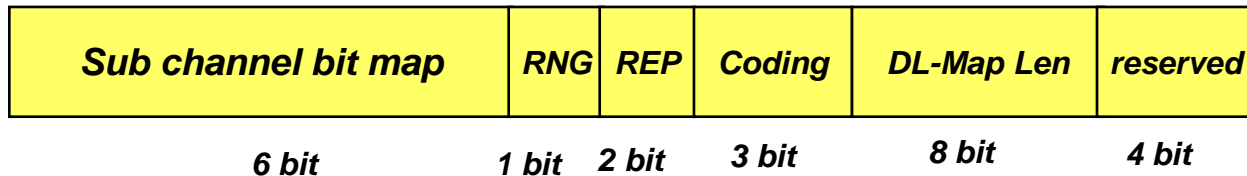

•Contents:

➤ **Used Subchannels bitmap**

Maps the used subchannels in the segment

Allocated subchannels are renumbered logically.

➤ **Ranging Change Indication**

➤ **DL-Map Coding parameters:**

- **Repetition Coding Indication (1,2,4,6)**

- **Coding Indication CC (mandatory), BTC, CTC or ZT CC**

- **DL-MAP Length**

➤ **Total 24 bits**

•Fixed Location and Coding:

- “First 4 slots of the segment” (8.4.4.4)

- QPSK rate $\frac{1}{2}$ with repetition coding of 4

DL-MAP Messages

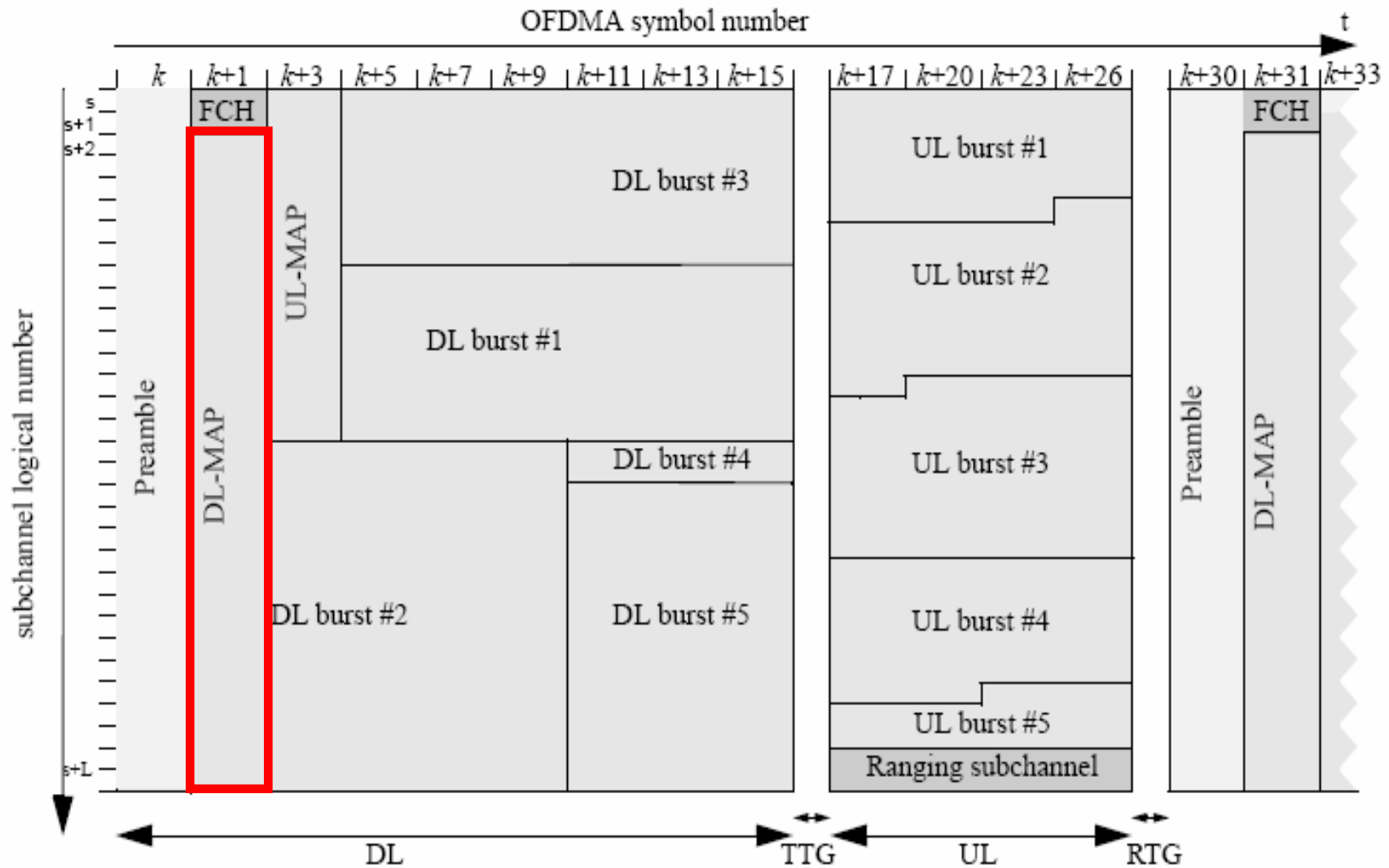

DL-MAP Messages

This is a management message:

- **GMH- Mgmt MSG**
- **PHY Synchronization**
 - Frame duration code (2-20 ms)
 - Frame number (24 bits)
- **DCD Count**
- **Base Station ID (48 bits)**
- **DL_MAP_IEs**
 - **Pointer to burst allocations**
 - **Total length in FCH**

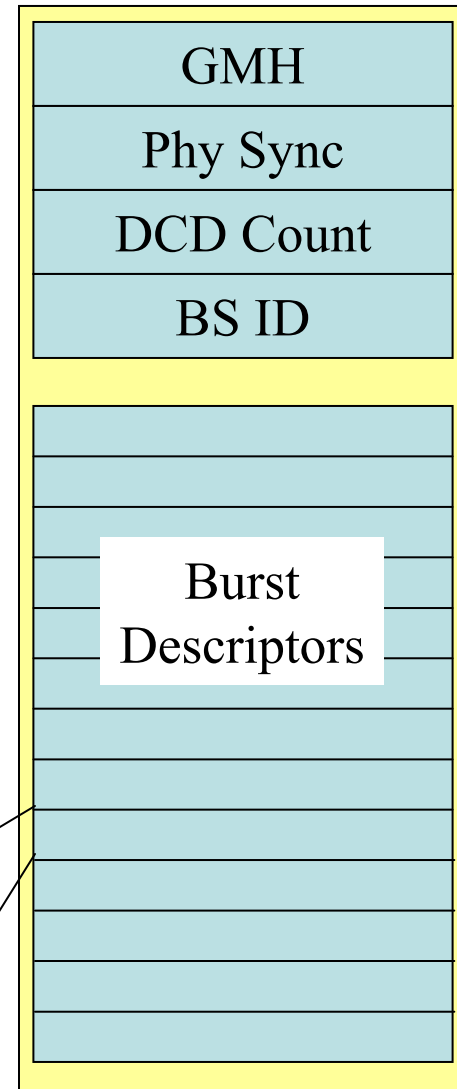
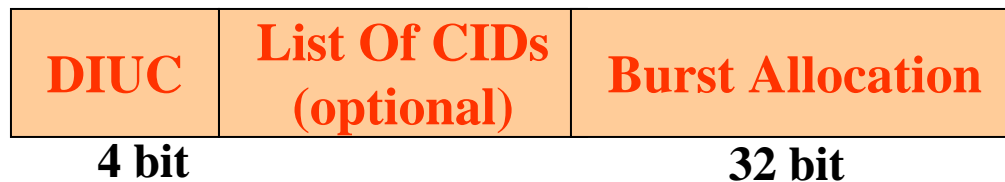

DL-MAP IE

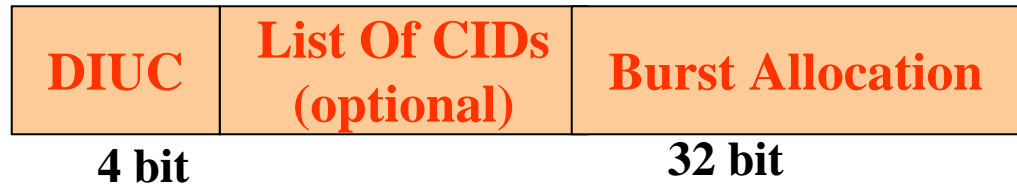

- Optional CID
 - Number of CIDs included (0-255)
 - CIDs List
- Burst Allocation:
 - OFDMA Symbol offset
 - Subchannel offset
 - Number of Subchannels
 - Number of OFDMA Symbols
 - Boosting (+6) to (-9) dB)
 - Repetition Coding Indication (1/2/4/6)

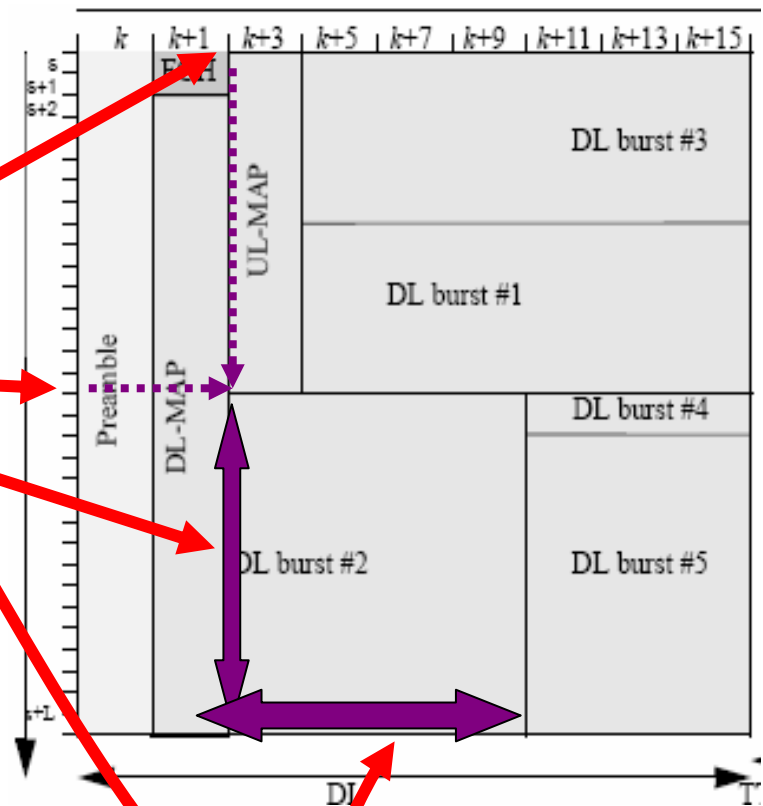

UL-MAP Messages

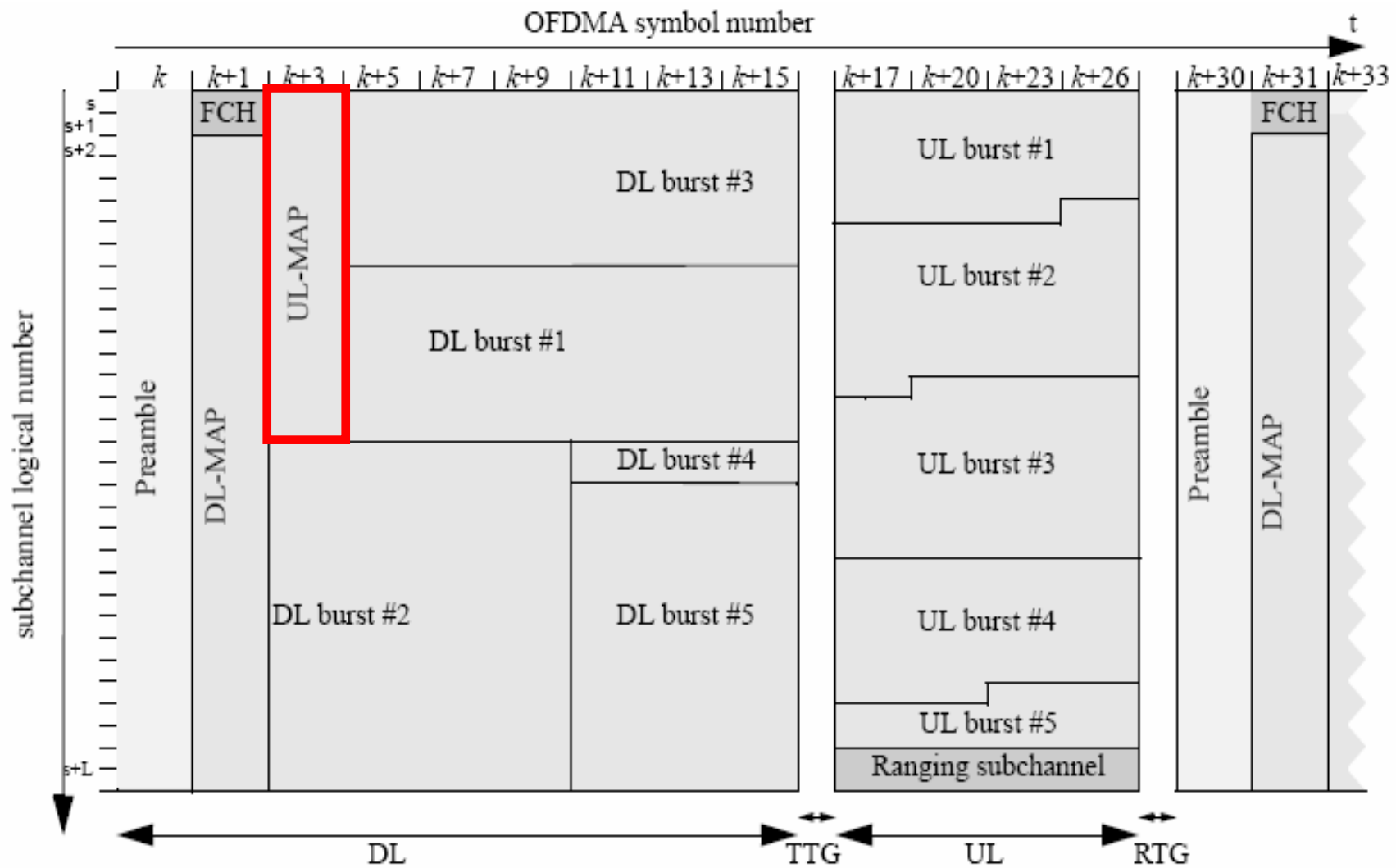

UL_MAP Messages

This is a management message, constant parts:

- **Uplink Channel ID**
- **UCD Count:** identify relevant UCD version
- **Allocation Start Time (UL_MAP relevance)**
- **UL_MAP_IEs**

802.16e Protocol Stack

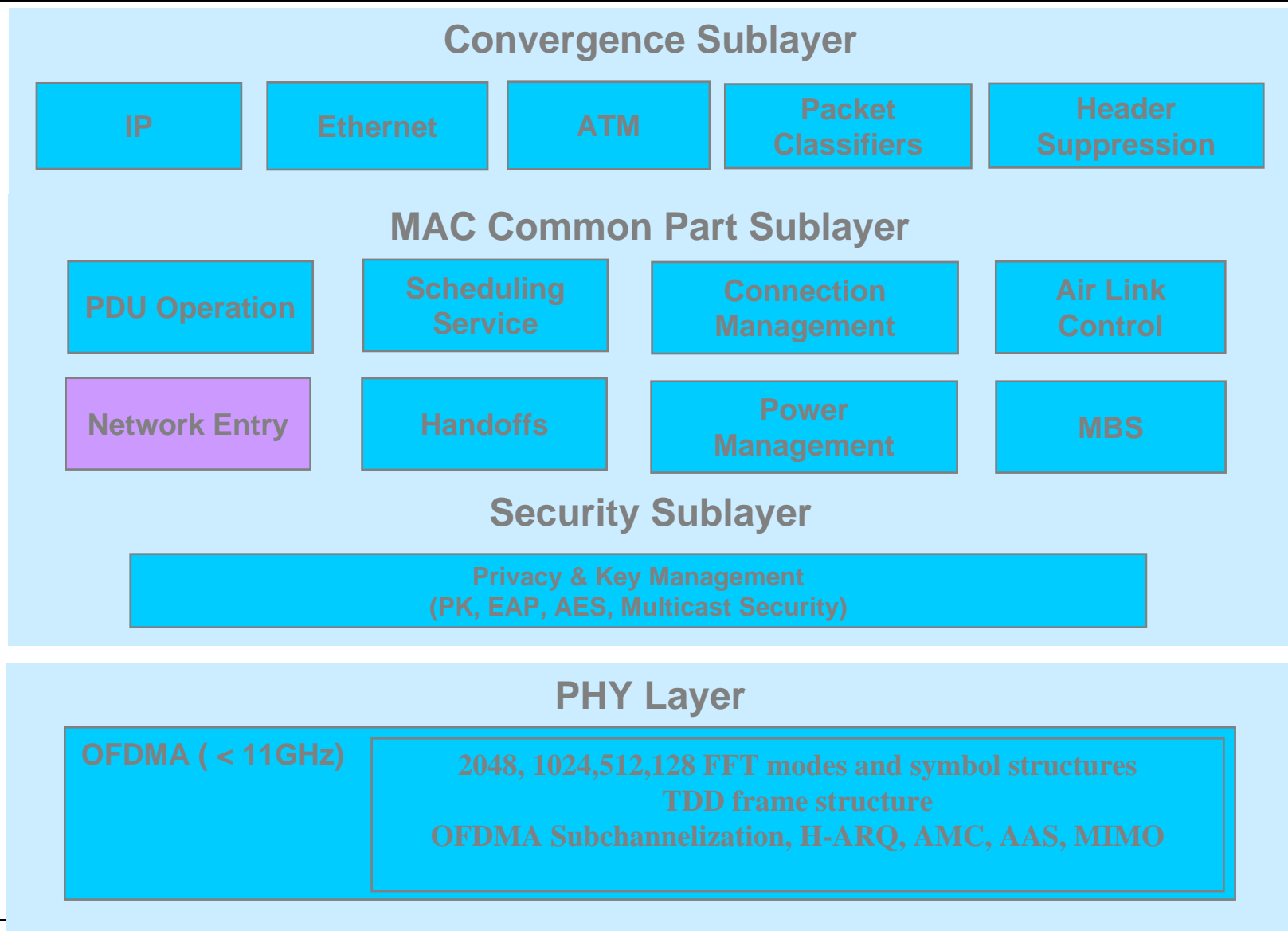

Network Entry and Initialization

- Purpose:
 - A SS needs to successfully complete the network entry process with the desired BS in order to communicate in the network.
- Procedure:
 - Scan for DL channel and establish sync with BS
 - Obtain transmit parameters (from UCD message)
 - Perform ranging
 - Negotiate basic capabilities
 - Authorize SS and perform key exchange
 - Perform registration
 - Establish IP connectivity
 - Transfer operational parameters
 - Set up connections

Network Entry Process

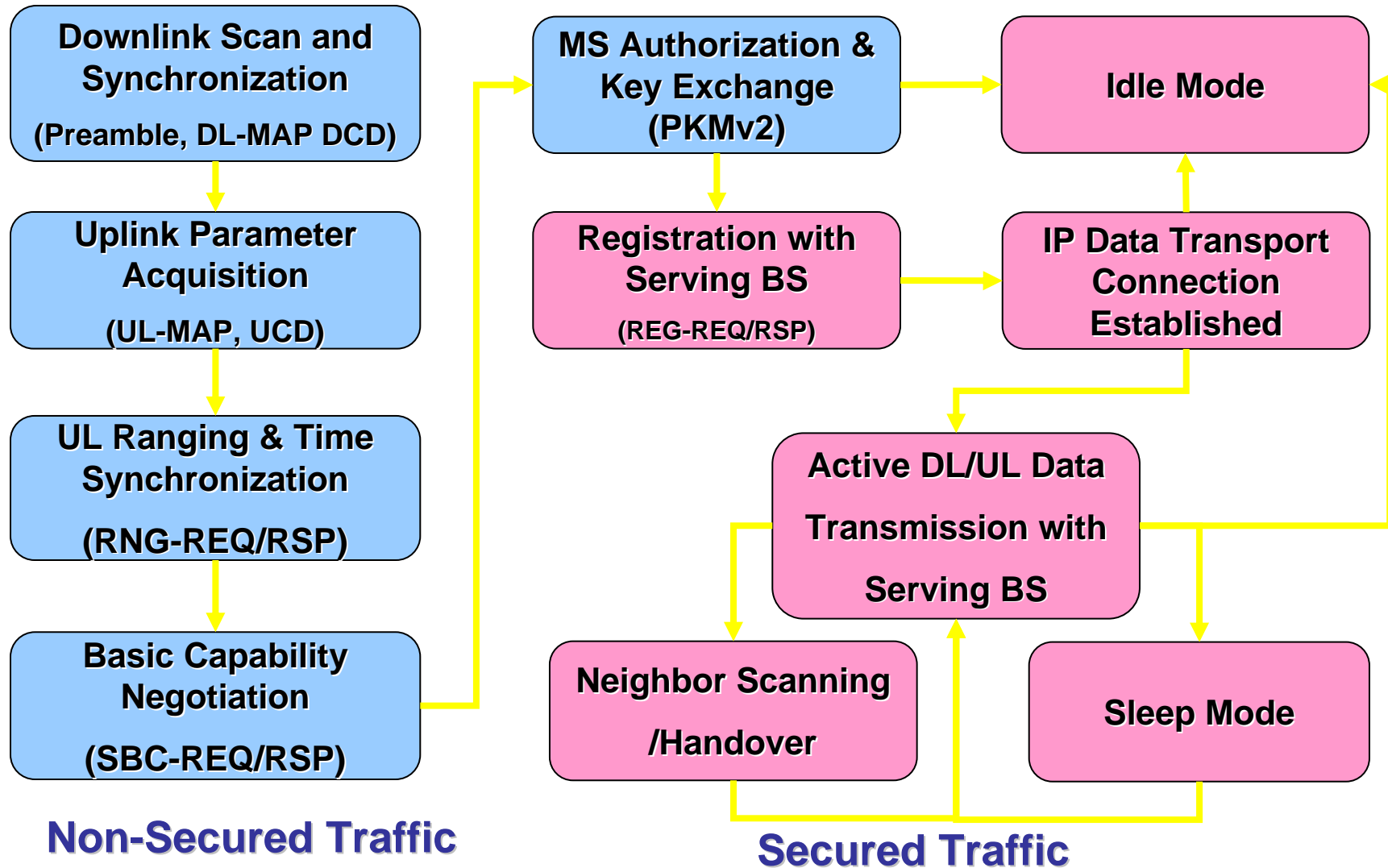

802.16e Protocol Stack

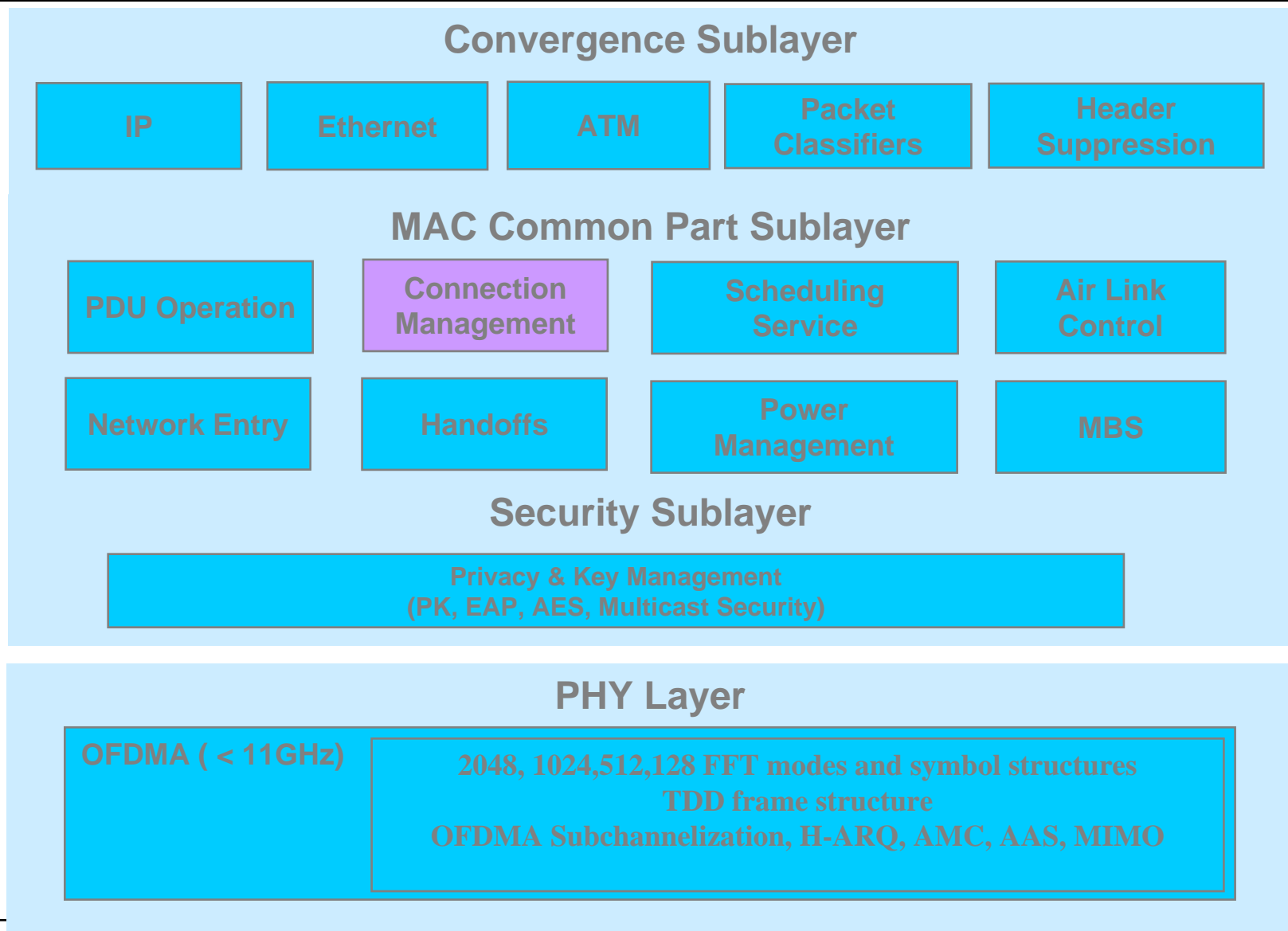

Connection

- Unidirectional logical link between BS and SS MAC
- A pointer to destination and context information
 - All service flows are transported over connection
 - Request for transmission is over connection
 - Each connection associated with certain QoS property
- Setup by BS based on provisions
 - SS registration
 - SS service modification
 - Basic connections established at initial ranging for delay- intolerant MAC management messages
- Multiple connection can be established for multiple service flows
- Higher layer sessions can share the same connection
- Connections share the air link

Service Flow

- A MAC Transport Layer for uni-Directional (Uplink or Downlink) transporting of packets
 - Characterize QOS parameters (latency, jitter, and throughput assurance)
 - Characterize bandwidth allocation process
 - QoS management for connection

Dynamic Service Flow

Service flows may be created, changed, or deleted. This is accomplished through a series of MAC management messages:

- DSA : create a new service flow
- DSC : change an existing service flow
- DSD : delete an existing service flow.

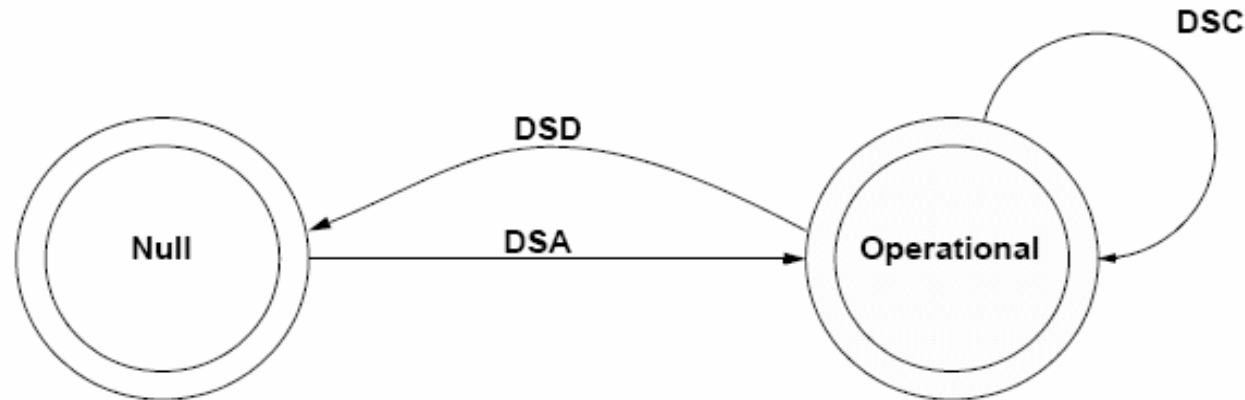

Figure 93—Dynamic service flow overview

QoS Theory of Operation

- Connection based QoS
 - Associate packets traversing MAC interface into service flow
 - Define QoS parameter set for each service flow
- QoS purpose
 - Define transmission ordering and scheduling on the air interface
 - Work in conjunction with mechanisms beyond the air interface to provide end-to-end QoS

QoS Requirements

- A function for preconfiguring SS-based QoS service flows and traffic parameters
- A function for dynamically establishing QoS-enabled service flows and traffic parameters
- Utilization of MAC scheduling and QoS traffic parameters for uplink service flows
- Utilization of QoS traffic parameters for downlink service flows
- Grouping service flow properties into service classes for upper-layer entities and external applications

QoS Types

QoS Category	Applications	QoS Specifications
UGS Unsolicited Grant Service	VoIP	<ul style="list-style-type: none"> •Maximum Sustained Rate •Maximum Latency Tolerance •Jitter Tolerance
rtPS Real-Time Packet Service	Streaming Audio or Video	<ul style="list-style-type: none"> •Minimum Reserved Rate •Maximum Sustained Rate •Maximum Latency Tolerance •Traffic Priority
ErtPS Extended Real-Time Packet Service	Voice with Activity Detection (VoIP)	<ul style="list-style-type: none"> •Minimum Reserved Rate •Maximum Sustained Rate •Maximum Latency Tolerance •Jitter Tolerance •Traffic Priority
nrtPS Non-Real-Time Packet Service	File Transfer Protocol (FTP)	<ul style="list-style-type: none"> •Minimum Reserved Rate •Maximum Sustained Rate •Traffic Priority
BE Best-Effort Service	Data Transfer, Web Browsing, etc.	<ul style="list-style-type: none"> •Maximum Sustained Rate •Traffic Priority



802.16e Protocol Stack

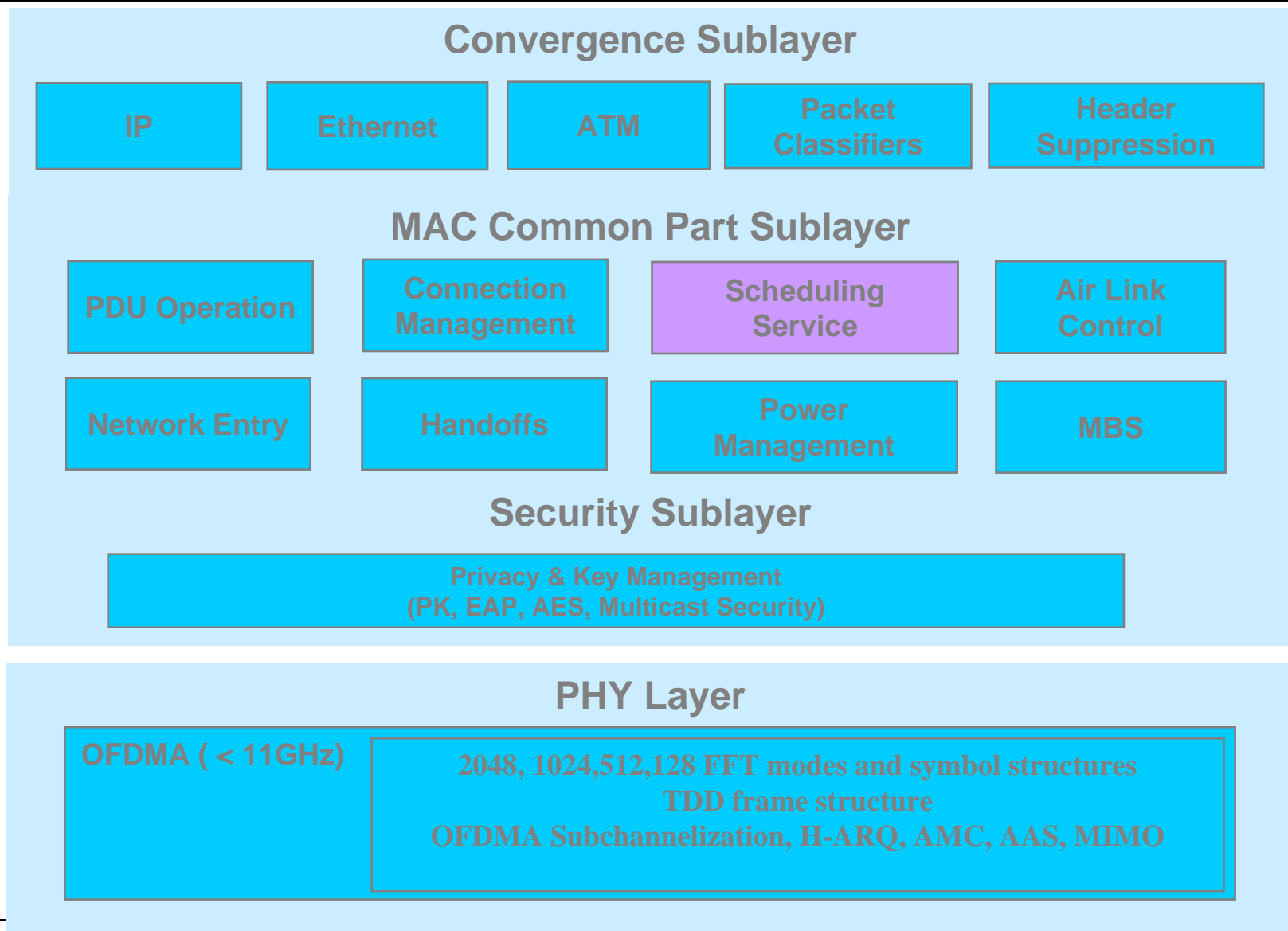

What is Scheduling Service?

- Data handling mechanism by MAC scheduler
- Service for data transport over connections
- Scheduling service to support
 - Connection QoS specification
 - Uplink bandwidth request
 - Optimal use of system resource

Connection Control Model

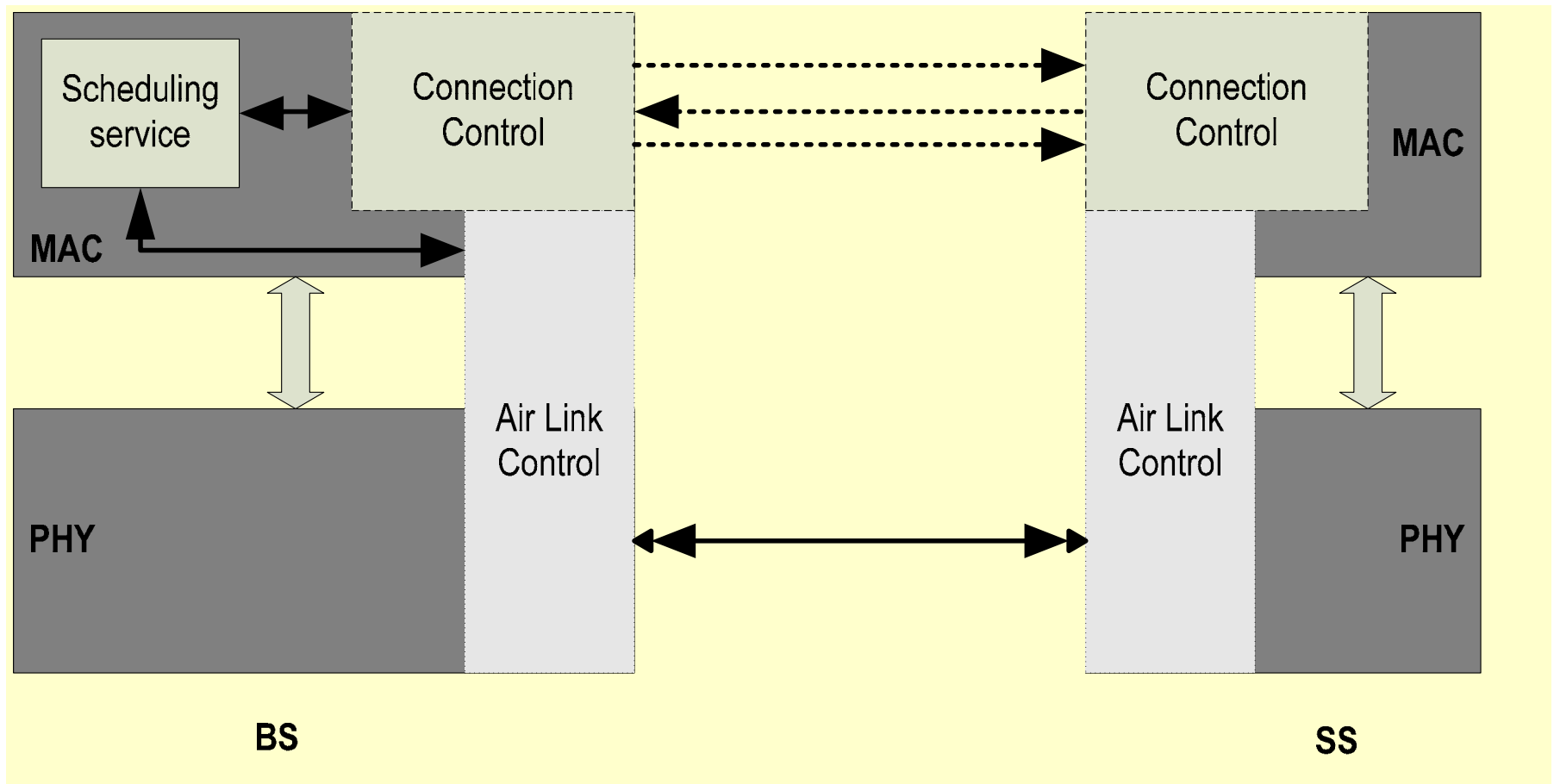

Bandwidth Request and Allocation

- Requests:
 - SSs indicate to the BS that they need UL bandwidth allocation
 - Stand-alone bandwidth request header
 - PiggyBack Grant Management subheader
- Polling:
 - BS allocates the SSs bandwidth to make bandwidth requests
 - Polling is done on SS basis
 - Unicast: SS is polled individually over basic CID
 - Multicast and broadcast:
 - Bandwidth allocation to multicast/broadcast CID
 - SSs perform contention resolution for bandwidth request
 - PM (poll-me) bit:
 - Only works for active UGS connections
 - Set the PM bit in a MAC packet to indicate the BS to poll
- Bandwidth request ranging:
 - SS contention based random access through CDMA ranging slot
- Grants:
 - Each bandwidth grant is addressed to the SS's basic CID. Grants are carried in UL-MAP messages

QoS Mechanism

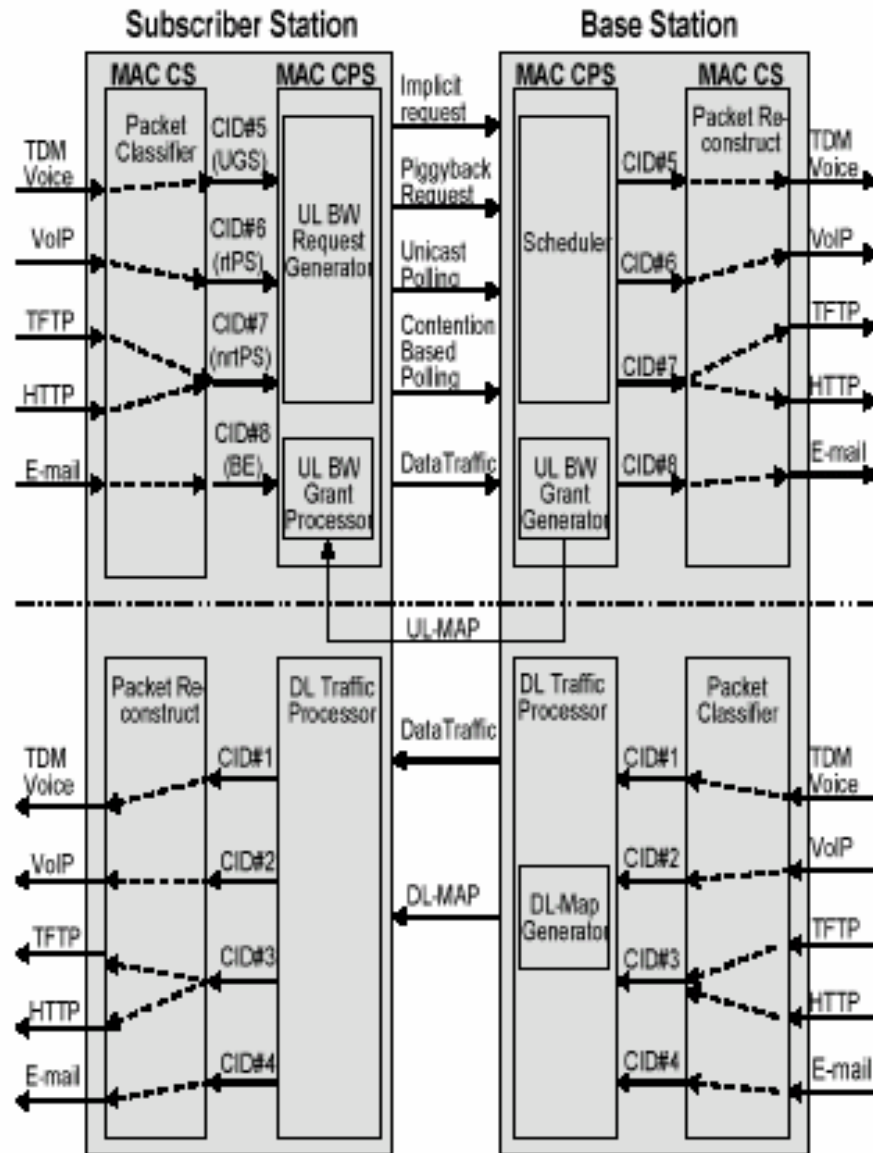

Scheduling System Considerations

- Total available bandwidth
- Service flow specific scheduling policy
- Service flow QoS parameters
- Data queue backlog
- Connection air link quality
- Impact of burst allocation on PHY
 - Burst concurrency
 - Interference property
 - Memory/processing limitation

802.16e Protocol Stack

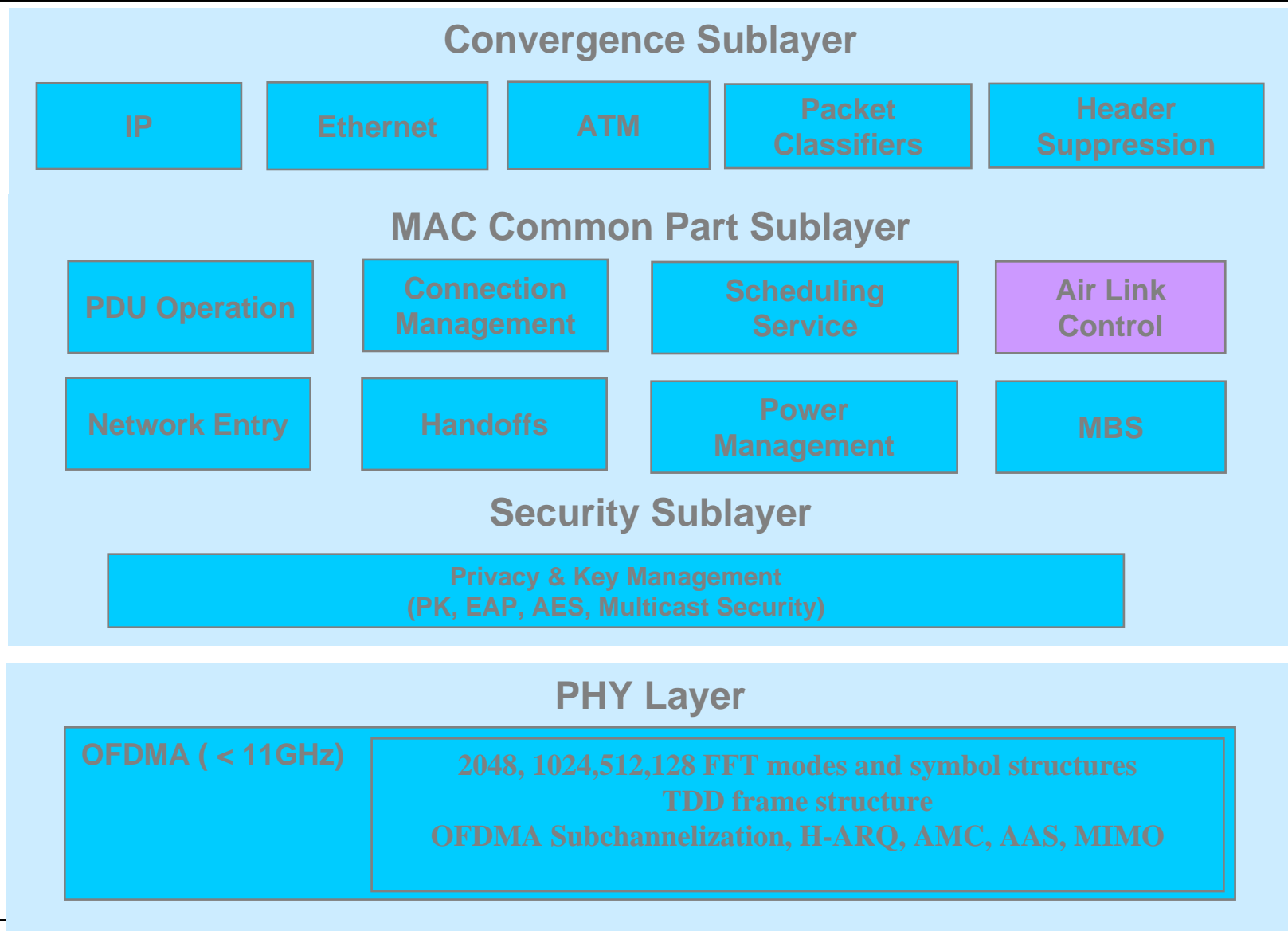

Connection Control Model

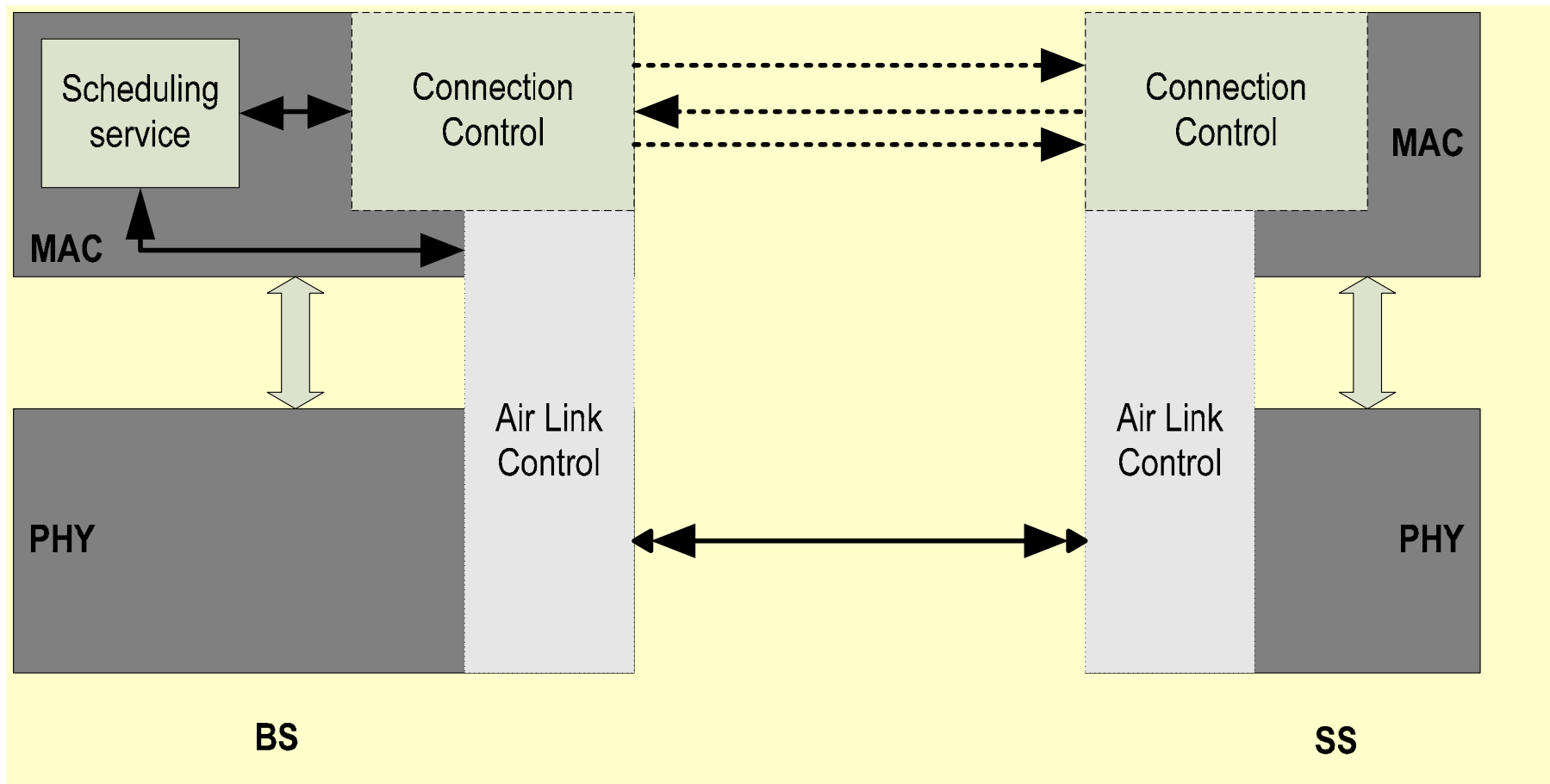

Air Link Control

- Ranging
- ARQ/HARQ
- Link adaptation
- Power control
- CQICH feedback

What is Ranging?

- SS contention access with CDMA code
- BS directed close-loop adjustments
 - Frequency offset
 - Time offset
 - Power offset
 - Bandwidth allocation
- Types:
 - Initial ranging/ Handoff ranging
 - Periodic ranging
 - BW request ranging

Ranging Requirements

- Stable performance
 - Initial ranging
 - Accurate UL parameter estimation and adjustment
 - Acceptable access latency
 - Periodic ranging
 - Accurate UL parameter estimation
 - On time parameters adjustment
 - BW request ranging
 - Low access latency
- Manageable complexity
 - Number of CDMA codes (M)
 - Multi-code detection and parameter estimation (K)
- Controlled overhead
 - Minimum 6~12 slots per ranging allocation
 - Rate of ranging allocation (T) – optimize (T,M,K)

ARQ and HARQ Options

- Automatic repeat request
 - Link error control
 - Reliable link over wireless channels
 - Suitable for delay tolerant traffic
- Layer 2 ARQ
- Layer 1 HARQ
 - Chase combining
 - Incremental redundancy

Layer 2 ARQ

- *Selective ACK* – Each bit at the ARQ ACK MAP refers to a block sequentially starting at the BSN block
- *Cumulative ACK* – All the blocks up to the BSN block are ACKed
- *Cumulative with Selective ACK* – combines the functionality of the two previous
- *Cumulative ACK with Block Sequence ACK* – 2 or 3 sequences of blocks can be ACK'd individually:
 - Sequence ACK Map - Determines if the blocks in this sequence are ACKed or NACKed.
 - Sequence # Length - Determines the length.
 - BSN is the first block at the first sequence.

HARQ

- Layer 1 stop-and-wait ARQ
- Dedicated ACK/NACK feedback channel
- Feedback with fixed delay
- Chase combining
 - Coherent combining
 - Apply to all coding/modulation
- Incremental redundancy
 - Incremental redundancy in successive retransmissions
 - Special coding format (CTC,CC)

ARQ/HARQ Summary

	Pros.	Cons.
ARQ	Simple layer 2 operation; Efficient selective feedback; Low overhead; Packets in order	Long delay; Feedback path not guaranteed
HARQ	Dedicated ACK/NACK channel; Low fixed feedback delay; CC/IR gain	High complexity receiver; Low efficiency stop and wait protocol; High feedback overhead; Packets out of order

Link Adaptation

- Adaptively select coding/modulation schemes based on channel condition
 - Maximize capacity
 - Stable operating point
- Link adaptation procedures
 - Receiver channel condition measurement
 - CINR, RSSI, N+I, instantaneous capacity, retries, packet drop count, PER
 - Receiver MCS prediction
 - Predict MCS in next frame based on past measurements
 - Connection QoS requirements
 - Transmitter MCS selection
 - MCS prediction
 - Other constraints: supported MCS subset, ARQ/HARQ, power control, scheduler and etc.

LA SINR/MCS Feedback

SINR Feedback

- SINR measurement at RX
- SINR feedback to TX
- TX predicts MCS level based on
 - SINR feedback
 - TX indirect measure
 - System constraints (QoS)
- TX selects MCS level based on
 - System constraints (QoS, throughput, outage)
 - TX MCS level prediction

MCS Feedback

- Direct channel measurements at RX
- RX predicts MCS level based on
 - RX measurements
 - System constraints (QoS)
- TX selects MCS level based on
 - RX MCS feedback
 - System constraints
 - TX indirect measurements

LA Block Diagrams

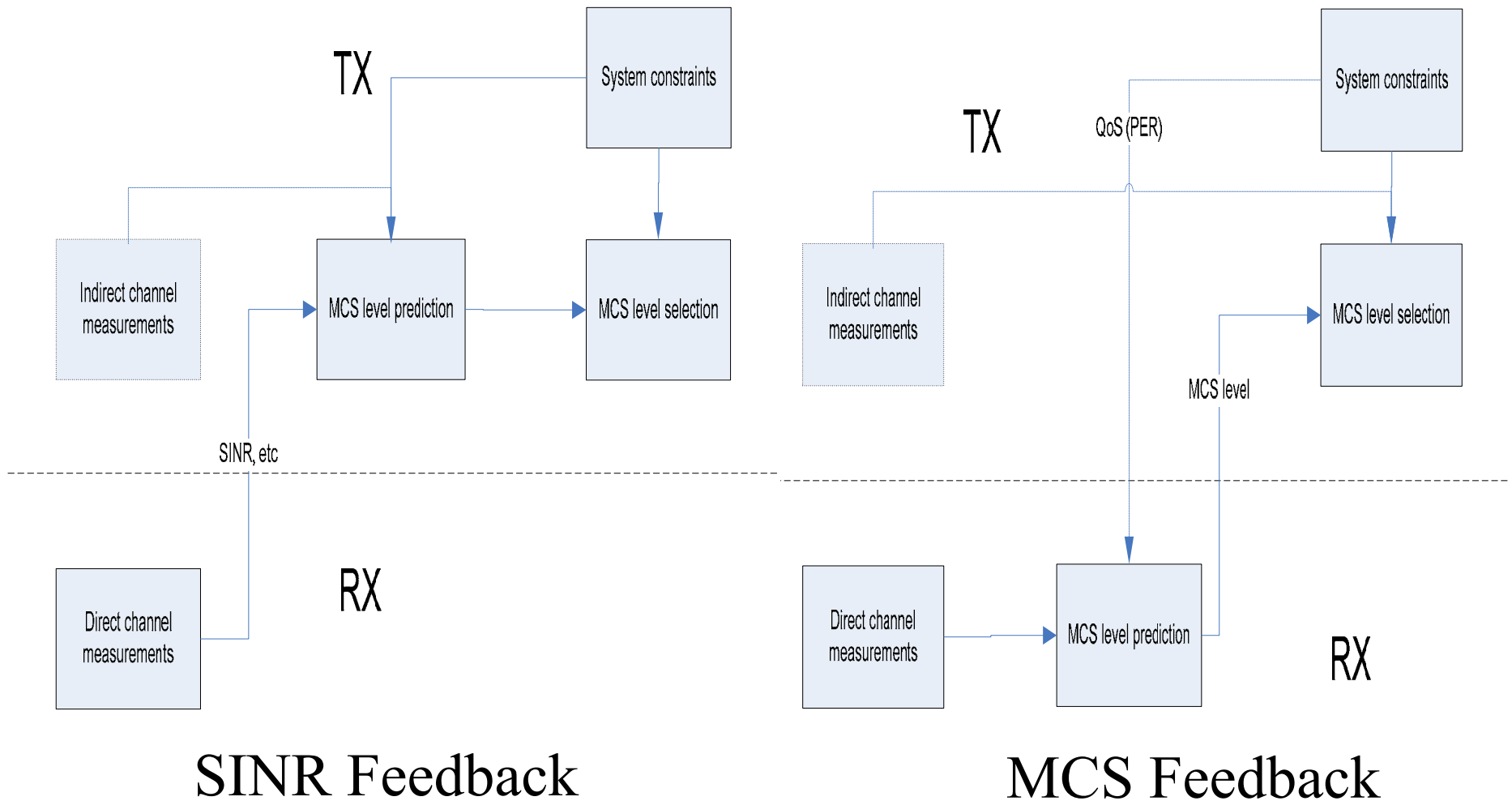

MCS Level vs. SINR

	SINR	MCS Level
Pros.	Predict full Rate-PER set from SINR	Full knowledge of channel measurements
	Easy to incorporate boosting effect; Good for max C/I scheduler	Full knowledge of receiver architecture Good for PF scheduler
Cons.	Lose information by quantizing channel measurements to SINR <ul style="list-style-type: none"> •Cannot fully reflect interference •Cannot easily factor in HARQ (progressive or heuristic) 	Single MCS feedback for a given set QoS constraints <ul style="list-style-type: none"> •QoS is well defined for each service flow •BS controls desired (Pkt Len, PER) •Bandwidth scale behavior can be predicted and controlled by BS
	Single SINR can not reflect proprietary SS receiver variation <ul style="list-style-type: none"> •Implementation loss •Receiver structure: estimation errors, multiple antenna •Decoder : input metric, iterations, suboptimal algorithms •Future improvement: multi-user detection 	Difficult to factor in boosting <ul style="list-style-type: none"> •progressive adjustment in multiple steps

Power Control

- Control received SINR by adjusting transmit power
 - Compensate path loss
 - Combat near-far problem
 - Control interference
 - Control power consumption
 - Power loading
- OFDMA power control requirements
 - Low intra-cell interference -> less near-far problem
 - Channel reciprocity -> open loop control
 - Adaptive MCS selection -> relaxed precision

Power Control Mechanisms

- Open loop power control
 - UL interference+noise level broadcasted in DL Map
 - Path loss estimate based on channel reciprocity
 - Power offset based on ACK/NACK
 - Fast power control (by UL-MAP fast tracking IE)
 - Broadcast power adjust to multiple MSs
 - Only when received packets from MSs in previous frame
- Close loop power control
 - Power adjustment sent in DL power control IE
 - Power adjust in 0.25dB step
 - Lack of dedicated uplink channel
- Power adjustment by periodical ranging

Fast Feedback

- Dedicated channels to provide fast feedback from SS
- Special allocation in UL sub-frame with simple mapping
- Types of feedback:
 - ACKCH
 - CQICH
 - SINR
 - MCS level selection
 - MIMO antenna weights (estimation)
- Feedbacks usages:
 - H-ARQ feedback (ACK / NAK)
 - Adaptive coding modulation (MCS selection)
 - Fast basestation switch (FBSS)
 - MIMO mode change

802.16e Protocol Stack

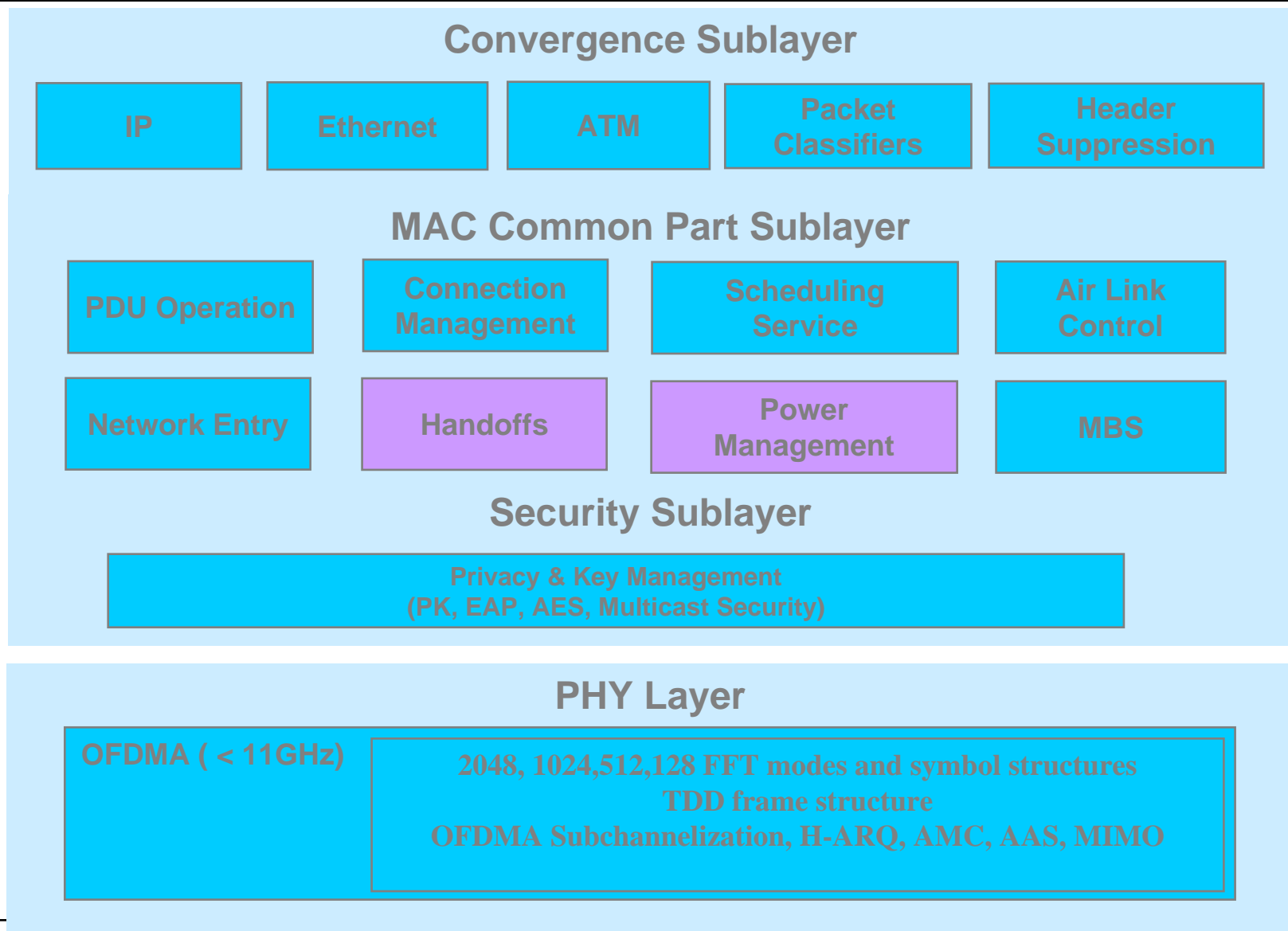

16e MM States

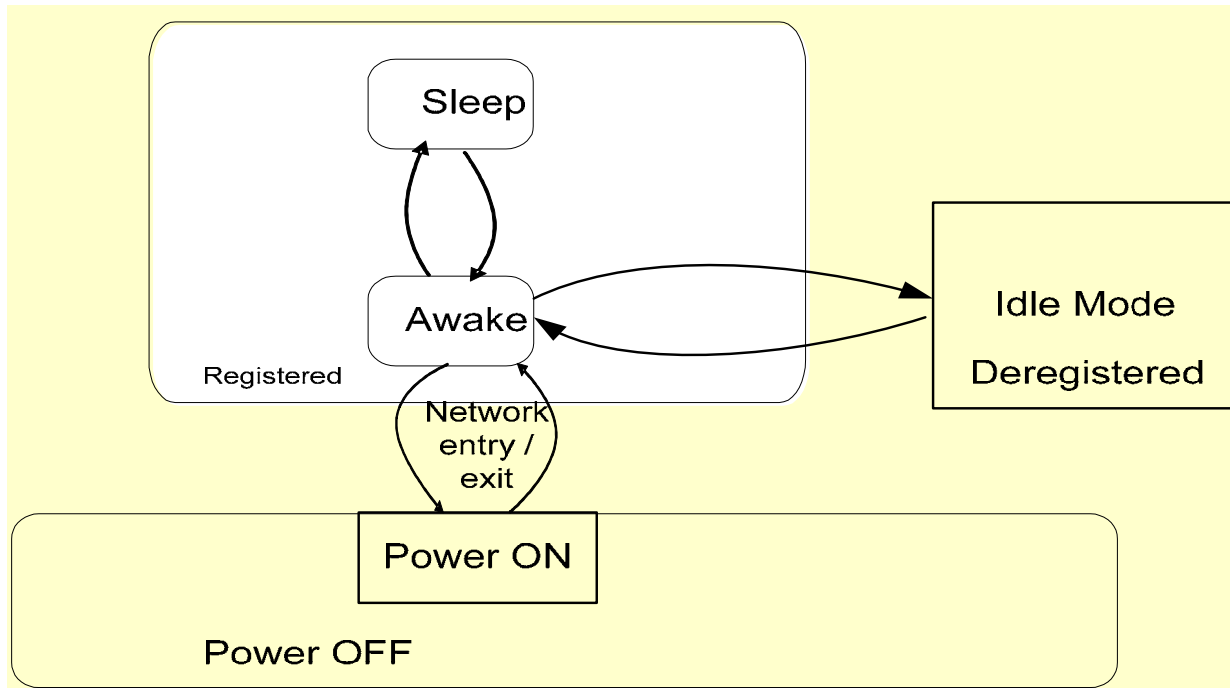

- Network (re)-entry
- Handover in connected mode
- Sleep mode
- Idle mode

Why Handover?

- When the MS can be serviced at a higher signal quality at another BS
 - MS moves
 - Signal fading
 - Interference
- When the MS can be serviced with higher QoS at another BS
 - Load balancing
 - Admission control
 - QoS expectation
- Essential to maintain connection and QoS in cellular network
 - Timely detecting the need of handoff
 - Efficient signaling to switch BS

Handover Overview

- Handover Schemes
 - Hard Handover (HHO)
 - Optimized Hard Handover (OHHO)
 - Fast Base Station Switching (FBSS)
 - Soft Handover (SHO)
- Handover Control
 - Mobile initiated
 - BS initiated
 - Network initiated
- Handover Scheduling
 - Non-overlapping Subchannels between sectors
 - Robust modulations in cell edge
- Cell Selection
 - Neighbor Advertisements from Serving BS
 - Periodic intervals for scanning neighbor BS's
- Security for Handover
 - 3-way Handshake for Authentication Key validation
 - TEK sharing for FBSS and SHO modes

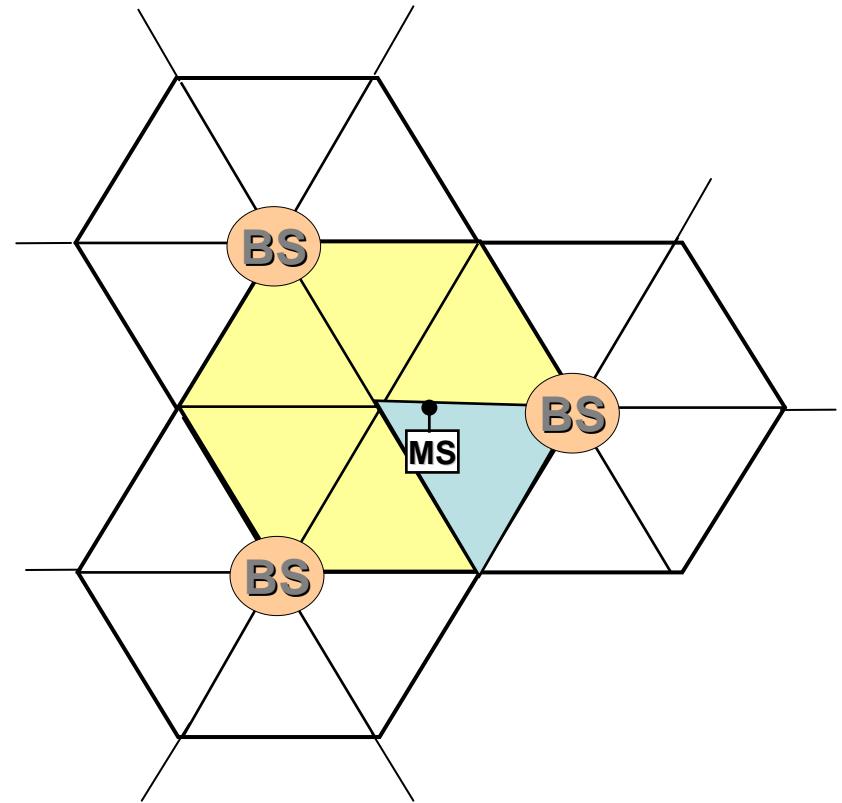

- ▲ Serving Sector
- ▲ Neighbor Sectors Scanned

Handover Procedures

- Network topology acquisition
 - Network topology advertisement
 - MS scanning
 - Association
- Handover process
 - Cell reselection
 - Handover decision & initiation
 - BS scanning
 - Network re-entry
 - Termination of service
 - Handover cancellation

Fast BS Switch (FBSS)

- Active set
 - MS and BS maintain a list of BSs that are involved in FBSS with the MS
- Anchor BS
 - A BS in active set
 - MS only communicates with the Anchor BS for UL/DL unicast traffic
- MS DL control/broadcast message monitoring
 - From Anchor BS
 - From all BSs in the active set
- No registration involved

FBSS Condition

- BSs in active set are synchronized on common time source
- Propagation delay difference between all BSs in active set to the MS is within the prefix interval
- BSs in active set have synchronized frame structure
- BSs in active set have the same frequency assignment
- BSs in active set share or transfer MAC context

Sleep Mode

- MS unavailable to DL/UL in pre-negotiated periods
- Normal operation during wake time
 - Maintain frame synch
 - Receive DL frames
- 3 Power Savings classes
 - per QoS flow-basis
- Sleep mode benefits
 - MS power conservation
 - BS air interface usage reduction

Sleep Mode Operations

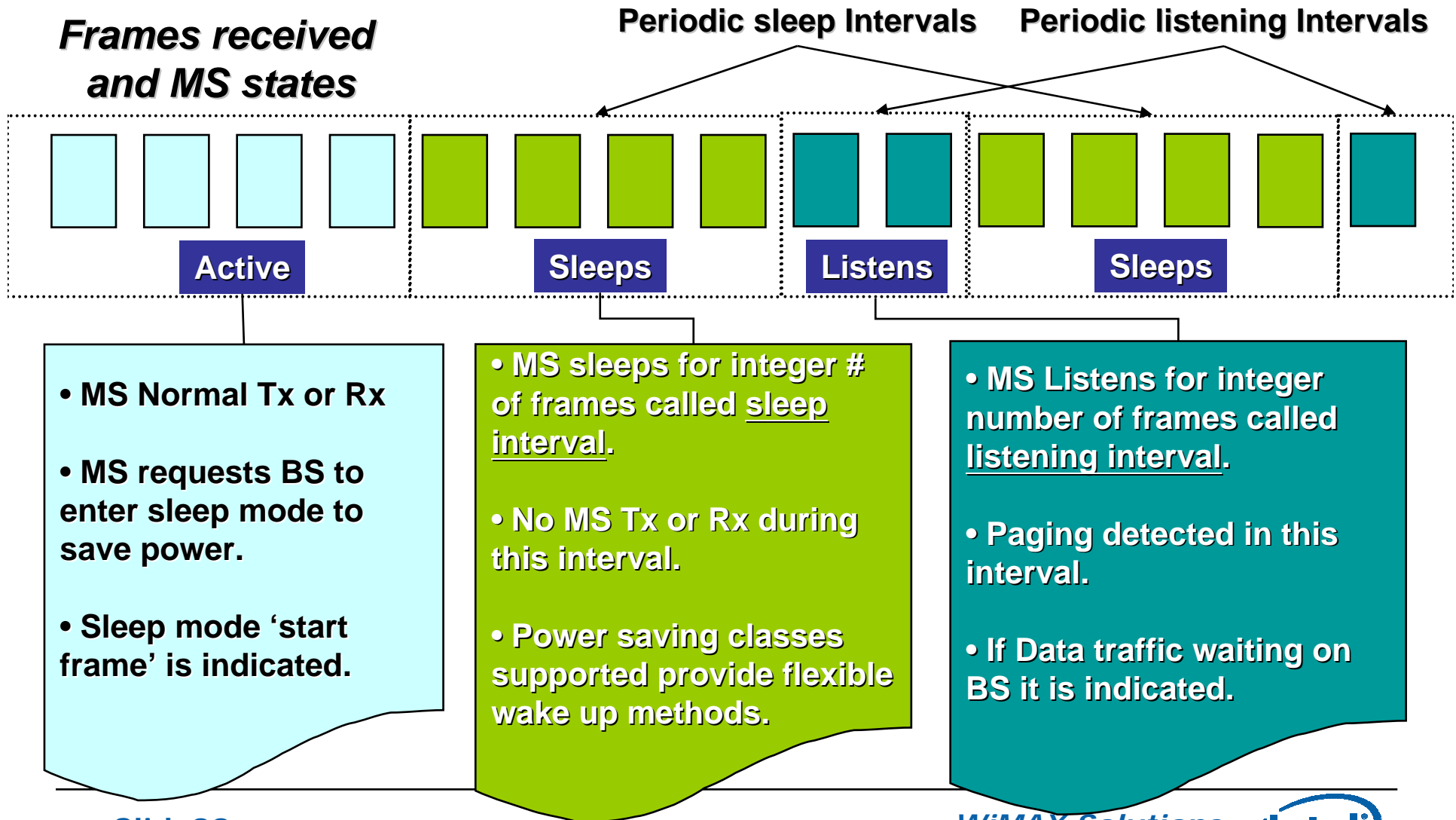

Paging

- To reach MS in idle mode
- Paging by DL broadcasting messages
- Covered by a group of multiple BSs
 - Large enough to cover idle mode MS mobility
 - Small enough to control paging overhead
- Controlled by paging controller

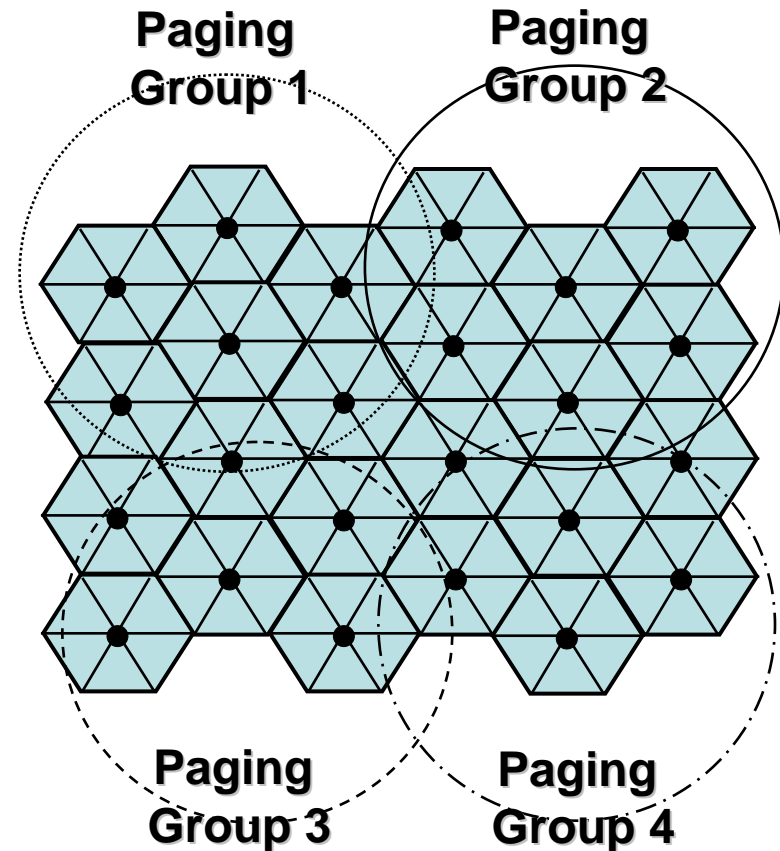

 BS with 6 sectors

802.16e Protocol Stack

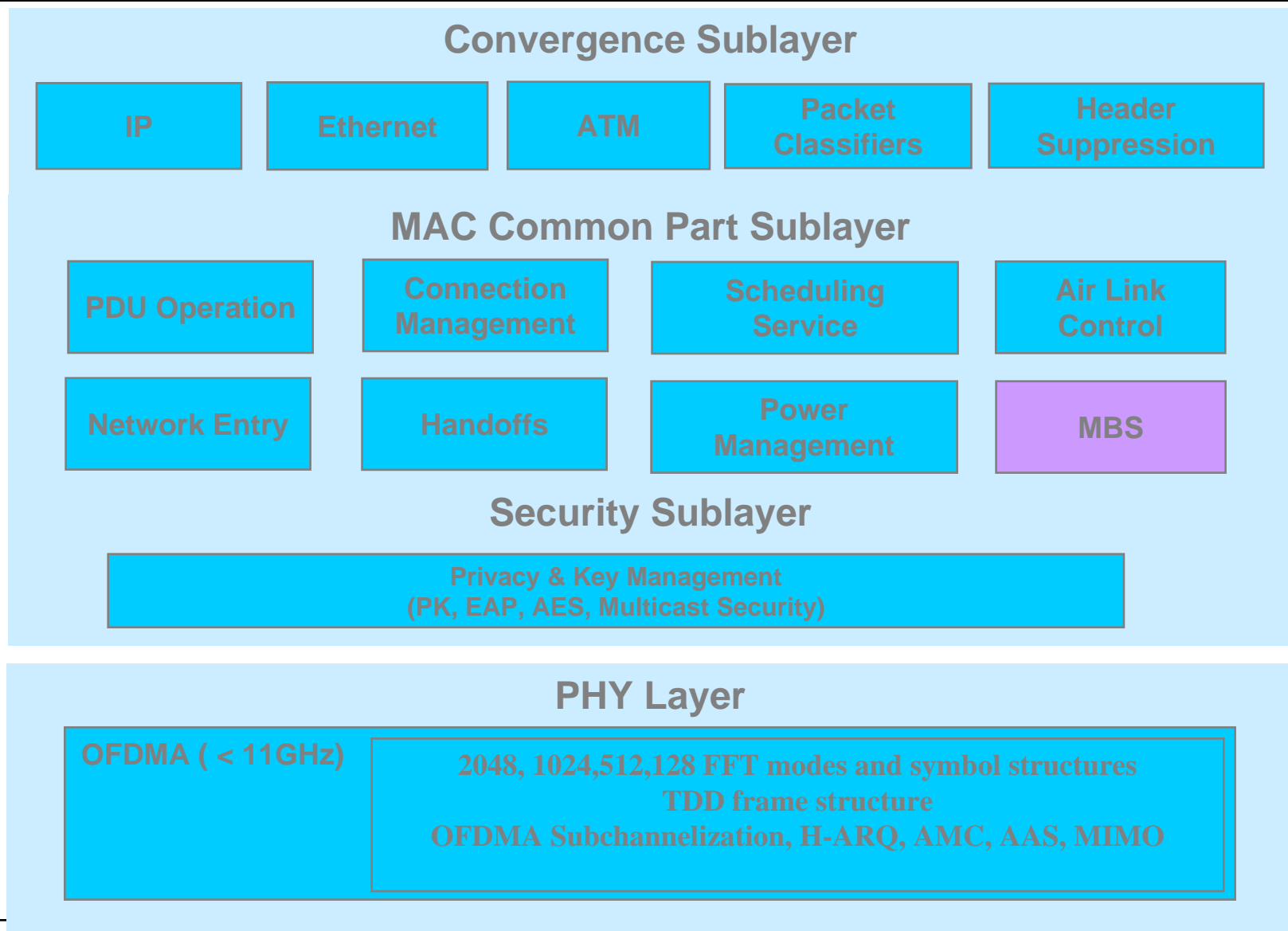

MBS

- Global defined service flow delivered to multiple MSs
- Single-BS access
 - BS creates multicast connection for a group of MSs
 - Same CID and SA
 - MBS_MAP_IE to point to MBS allocation
- Multi-BS access
 - BSs in MBS synchronized in MBS data transmission
 - BSs form MBS-zone
 - Same CID and SA for BSs and MSs
 - MS register to MBS at connected mode
 - MBS accessible even in idle mode in MBS zone

802.16e Protocol Stack

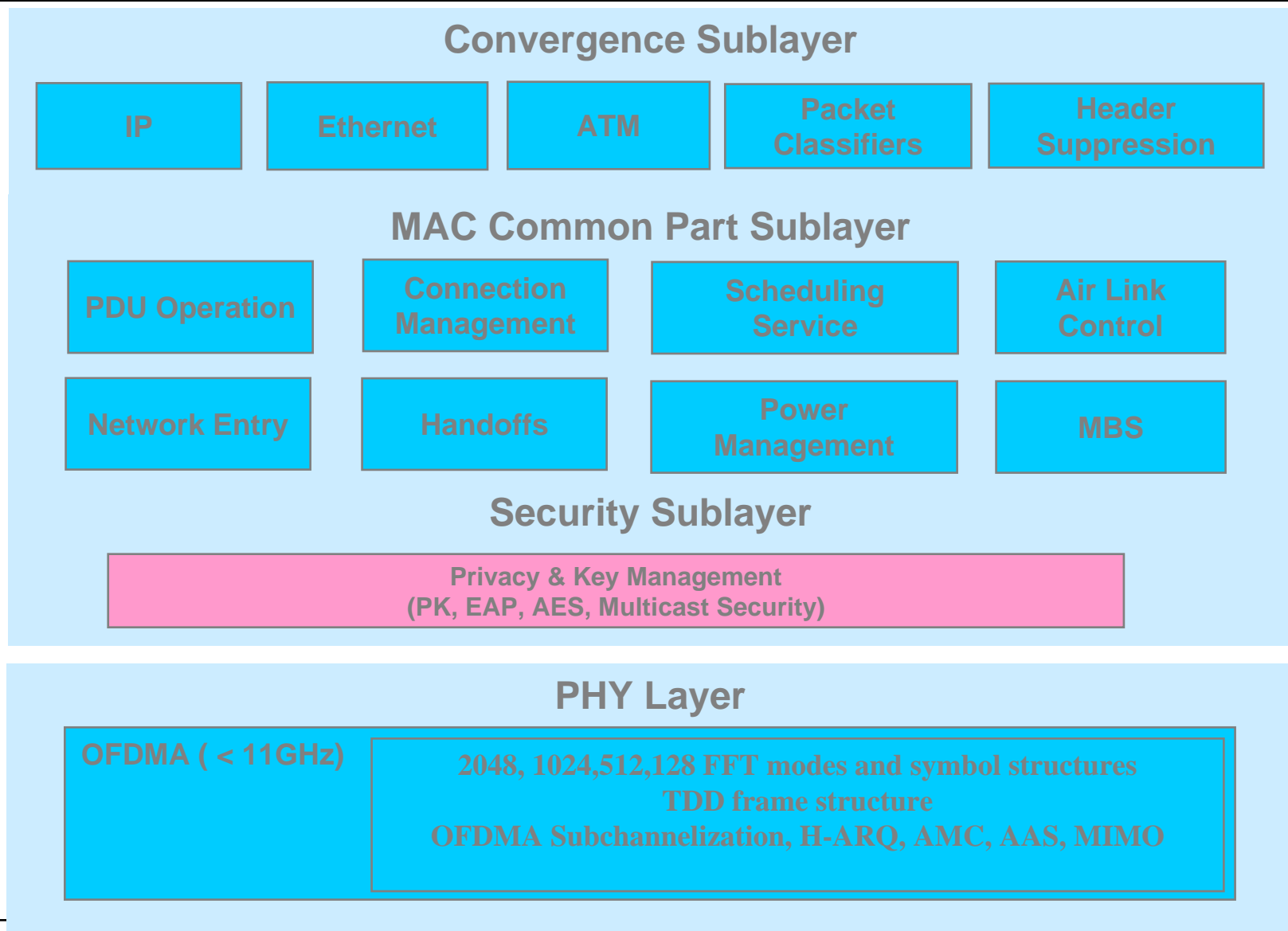

Security Features

- **Authentication**
 - X.509 certificates using RSA or EAP-TLS authentication
 - SIM, USIM, SmartCards using EAP-SIM, EAP-AKA, EAP-SmartCard methods
 - Other EAP method based credentials
- **Key Management**
 - Privacy Key Management Protocol (v2). Native 802.16 protocol for enhanced 802.1X like functionality
 - Authentication, Integrity, Handshake and Traffic Encryption Keys
 - Key contexts, Security Associations and Lifetime management
 - Broadcast, multicast keys
- **Control Message Protection**
 - FIPS* approved CMAC & HMAC message authentication
- **Traffic Protection Cipher Suites**
 - FIPS approved AES-CCM authenticated data encryption (like 802.11i)
 - Traffic Encryption Key refresh mechanism for high data rates

*Federal Information Processing Standards

Security Architecture

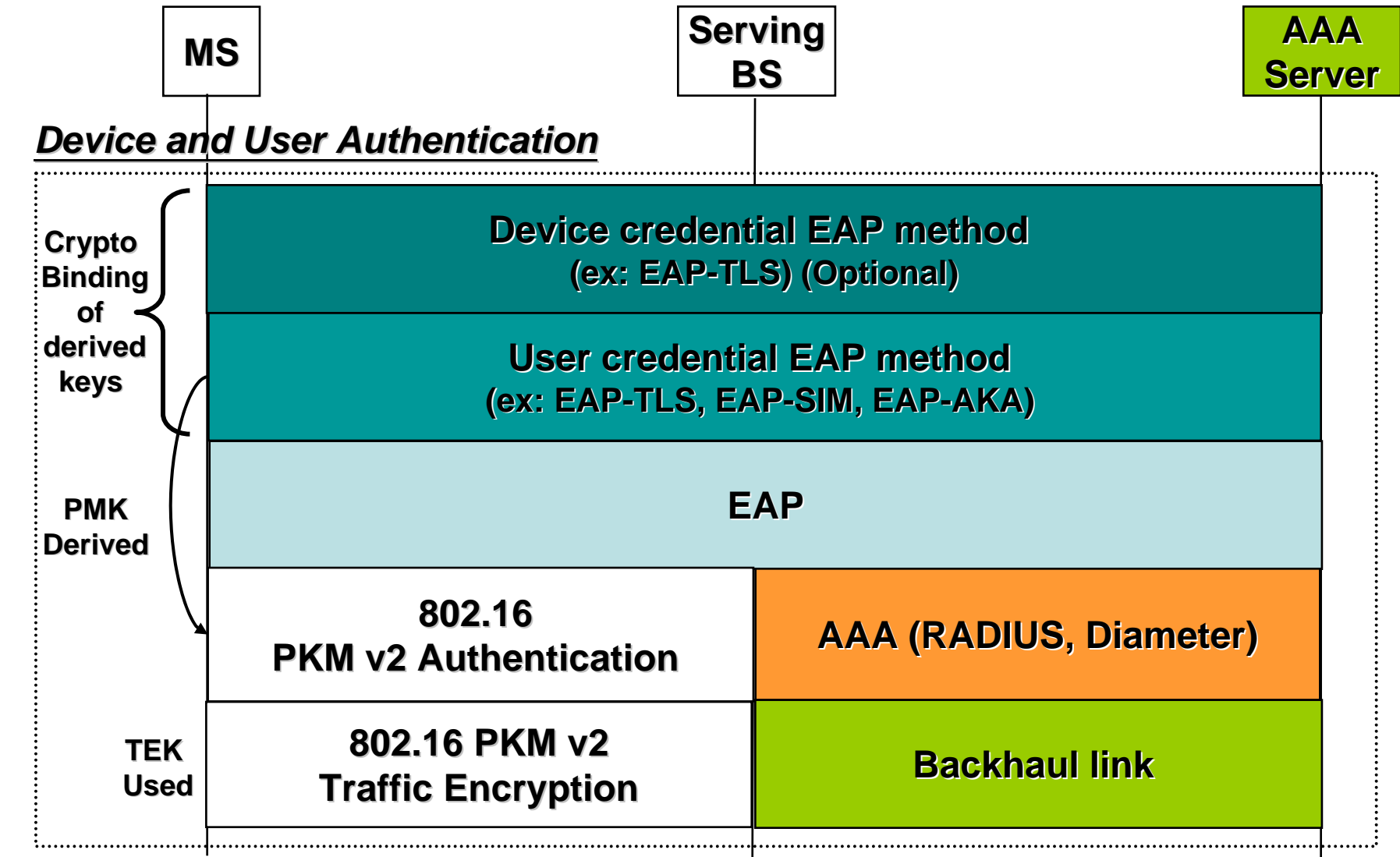

MAC Profile and Certification (1/2)

Release 1 MAC Profile		Wave 1*	Wave 2	Comments
Convergence Sublayer	Packet Header Suppression (PHS)	●	●	
	IPv4	●	●	
	IPv6		●	
	IPv4 with ROHC		●	
	IPv6 with ROHC		●	
	Ethernet	Optional	Optional	
MAC PDU Formats	Packing/Fragmentation	●	●	
	Packing ARQ Feedback Payload		●	
ARQ	MAC ARQ	●	●	
PHY Support	H-ARQ Support	●	●	
	Feedback Mechanism		●	
QoS and Data Delivery Services	BS Initiated Service Flows	●	●	
	MSS Initiated Service Flows		●	
	UGS	●	●	
	RT-VR		●	
	NRT-VR		●	
	BE	●	●	
	ERT-VR	●	●	
Request-Grant Mechanism	Request-Grant Mechanism	●	●	

* Wave 1 Feature Set based on results of Feb'06 WiMAX Forum



Mobile WiMAX

Release 1 MAC Profile and Certification

Release 1 MAC Profile		Wave 1*	Wave 2	Comments
General Handover	HO initiated by BS		●	
	HO initiated by MSS	●	●	
Handover	Neighbor Advertisement	●	●	
	Scanning	▲	●	
	HO Optimization	▲	●	
	CID & SAID Update	●	●	
Sleep-Idle	Sleep Mode	▲	●	
	Idle Mode	▲	●	
	Expedited Network Re-entry from Idle	●	●	
Cryptographic Suites	No data encryption, no data authentication, & 3-DES, 128	●	●	
	CCM-Mode 128-bit AES, CCM-Mode, AES Key Wrap with 128-bit key	●	●	
Security	PKMv2	●	●	
	CMAC	●	●	
	Security Associations	●	●	
MBS (IO-MBS for BS)	Multi-BS MBS		●	
Miscellaneous	MSS Network Entry issued by BS	●	●	
	Multicast Traffic Connection		●	

* Wave 1 Feature Set based on results of Feb'06 WiMAX Forum

Slide96

● Full Support ▲ Partial Support

WiMAX Solutions
Division

